

ANALYSIS OF FUEL CELL POWERED EV CHARGING STATION

¹Bondu Pavan Kumar Reddy, ²Dr. Vyza Usha Reddy.

^{1 2}Department of EEE, Sri Venkateswara University College of Engineering, Tirupati, India

¹ <http://orcid.org/0000-0001-8845-571X>, ² <http://orcid.org/0009-0004-7070-8925>

E-mail: ¹ pavankumar.eee216@gmail.com, ² vyza_ushareddy@yahoo.co.in

ARTICLE INFO

Article History

Received: September 11th, 2024

Revised: October 10th, 2024

Accepted: October 11th, 2024

Published: October 31th, 2024

Keywords:

Fuel Cell,
EV Charging,
Zeta Topology,
SEPIC Topology,
Modified SEPIC topology.

ABSTRACT

The paper offers a comparative performance analysis of fuel cell-powered EV charging systems utilizing ZETA, SEPIC, and modified SEPIC DC-DC converter topologies. Despite the cleaner energy source that fuel cells represent, their high cost has limited their penetration in EV charging. Selecting a suitable DC-DC converter topology is crucial for achieving fast charging and improved efficiency. The paper presents a performance analysis of the ZETA, SEPIC, and modified SEPIC converter topologies, both with open-loop and closed-loop control, for EV charging applications. A MATLAB/Simulink model was developed to examine the performance of these topologies in terms of battery state of charge (SoC), battery voltage, and charging current. The study reveals that the battery charged from an SoC of 50% to 50.03% using the modified SEPIC converter, while the ZETA and SEPIC converters charged to 50.024% under closed-loop control. Under open-loop control, the modified SEPIC charged to 50.025%, followed by ZETA at 50.024% and SEPIC at 50.02%, with a similar simulation time of ten seconds using a fuel cell as the primary energy source. The results demonstrate that the DC-DC modified SEPIC converter outperforms both ZETA and SEPIC converters.



Copyright ©2024 by authors and Galileo Institute of Technology and Education of the Amazon (ITEGAM). This work is licensed under the Creative Commons Attribution International License (CC BY 4.0).

I. INTRODUCTION

Fuel cells, a type of electrochemical device, have emerged as a promising alternative to traditional internal combustion engines and lithium-ion batteries in electric vehicles (EVs). They offer a clean and efficient way to generate electricity, producing only water and heat as byproducts, making them a desirable option for reducing greenhouse gas emissions and improving air quality [1].

The basic structure of fuel cell is depicted in figure 1. The operating principle of a fuel cell involves the electrochemical reaction between a fuel (typically hydrogen) and an oxidant (usually oxygen) to produce electricity, water, and heat.

This process is highly efficient and can deliver a continuous supply of power, making it suitable for powering EVs. Based upon the type of membrane used, the fuel cells are classified as [2].

Proton Exchange Membrane (PEM) fuel cells: These are the most common type of fuel cell used in EVs. They use a proton exchange membrane (PEM) to conduct protons from the anode to

the cathode. PEM fuel cells operate at relatively low temperatures and can be started quickly, making them suitable for transportation applications.

Alkaline fuel cells (AFCs): AFCs use a hydroxide ion-conducting electrolyte. They offer high efficiency and can operate at relatively low temperatures. However, they are sensitive to carbon dioxide contamination, which can limit their use in certain applications.

Solid Oxide Fuel Cells (SOFCs): SOFCs use a solid ceramic electrolyte. They operate at high temperatures, which allows them to use a variety of fuels, including natural gas and biogas. However, the high operating temperature can pose challenges for integration into vehicles.

Phosphoric Acid Fuel Cells (PAFCs): PAFCs use phosphoric acid as the electrolyte. They operate at intermediate temperatures and are relatively tolerant to impurities in the fuel. PAFCs are used in stationary power generation applications.

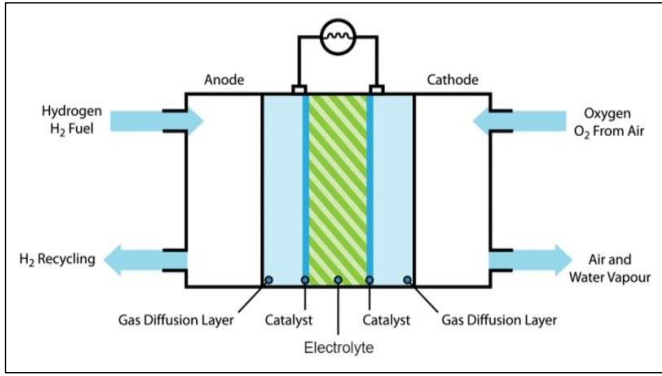

Figure 1: Fuel cell Architecture.
Source: Authors, (2024).

Despite their advantages, the penetration of fuel cells in EV charging has been relatively limited. Several factors have contributed to this, including high cost, infrastructure limitations, range anxiety and technical challenges. However, significant advancements have been made in recent years to address these challenges and improve the feasibility of fuel cell vehicles [3]. Fuel cell and Hydrogen Energy Association (FHCEA), a USA based non-profit organisation is planning for mobile EV charging stations using hydrogen fuel cells by 2026.

II. MODELLING & DESIGNING

The MATLAB/Simulink Solar PV system was developed to charge EV battery with specifications of 48V, 200Ah through DC-DC Converters with a fuel cell of nominal power 1.26kW. The fuel cell stack design parameters are represented in the Table 1[4] and the parameters for ZETA, SEPIC (Table 2) and Modified SEPIC converters when employed for EV charging form fuel cell are calculated and presented in Table 3 [5-7].

Table 1: Fuel cell Specifications.

Parameter	Specification
Nominal Voltage	24.23V
Nominal Current	52 A
Nominal Power	1.26 kW
Maximum Power	2 kW
No. of Cells	42
Stack Efficiency	46 %

Source: Authors, (2024).

Table 2: Parameters for various Converters.

Parameter	ZETA Converter	SEPIC Converter	Modified SEPIC converter
Duty Cycle	66.4 %	66.4 %	32.9
Inductor (L ₁)	38.6 μH	38.6 μH	76 μH
Inductor (L ₂)	38.6 μH	38.6 μH	76 μH
Capacitor (C ₁)	1.8 mF	3.5 mF	1.43 V
Capacitor (C ₂)	4.3 μF	1.8 mF	0.9 mF

Source: Authors, (2024).

Table 3: Battery Specifications.

Parameter	Specification
Capacity	200 Ah
Nominal Voltage	48 V
Nominal Power	9.6 kWh
Cut-off Voltage	40.5 V
Maximum Voltage	52.3 V

Source: Authors, (2024).

A real-world economically available four-wheeler battery, such as those used in electric vehicles like the Reva-i car, Mahindra E20, and battery-operated golf carts, was considered for analysis in this study. This battery has a capacity of 9.6kWh and was charged using a 2kW fuel cell through various converters to evaluate their performance.

III. SIMULATION & RESULTS

An EV battery pack with a rating of 48V, 200Ah is charged through a 2kW PV source with ZETA, SEPIC & modified SEPIC converters are simulated in MATLAB/Simulink Environment. In simulation testing, the parameters such as voltage and current from fuel cell along with battery SoC, Charging current and battery voltage are observed at the same test conditions for both converters. The figures from 2 to 15 illustrates MATLAB/Simulink model, fuel cell characteristics (i.e., Voltage and Current), battery SoC, battery charging current and battery voltage of ZETA, SEPIC & modified SEPIC converters with open loop & closed loop control strategies.

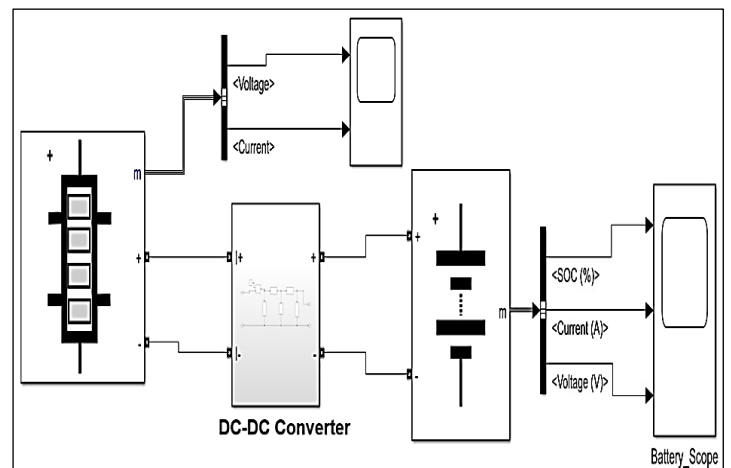

Figure 2: MATLAB/Simulink Model of open loop fuel cell based EV charging system.
Source: Authors, (2024).

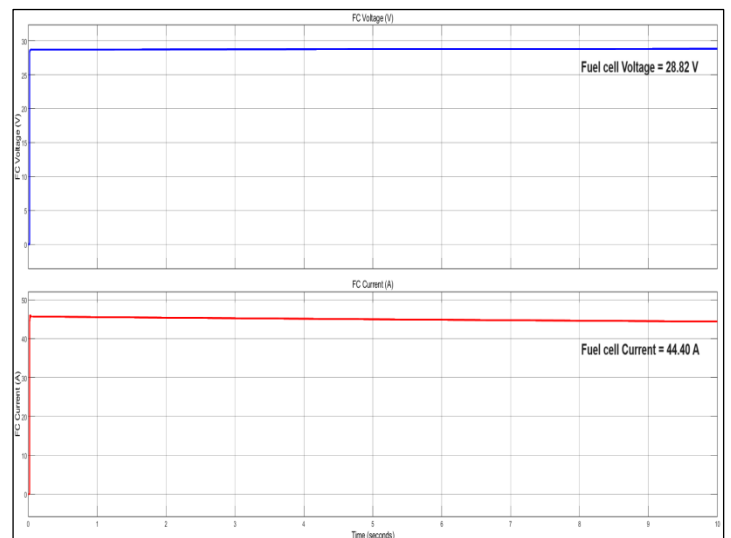

Figure 3: Characteristics response of open loop PEMFC based EV charging with ZETA converter.
Source: Authors, (2024).

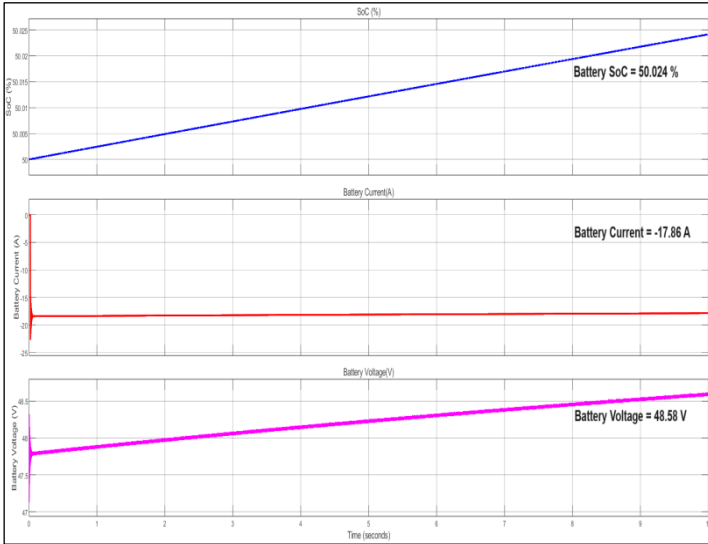

Figure 4: Battery charging results of open loop PEMFC based EV charging with ZETA converter.
Source: Authors, (2024).

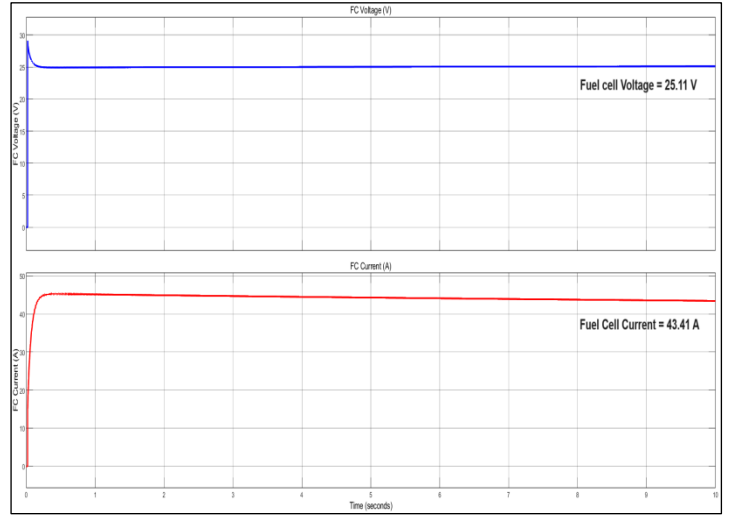

Figure 7: Characteristics response of open loop PEMFC based EV charging with modified SEPIC converter.
Source: Authors, (2024).

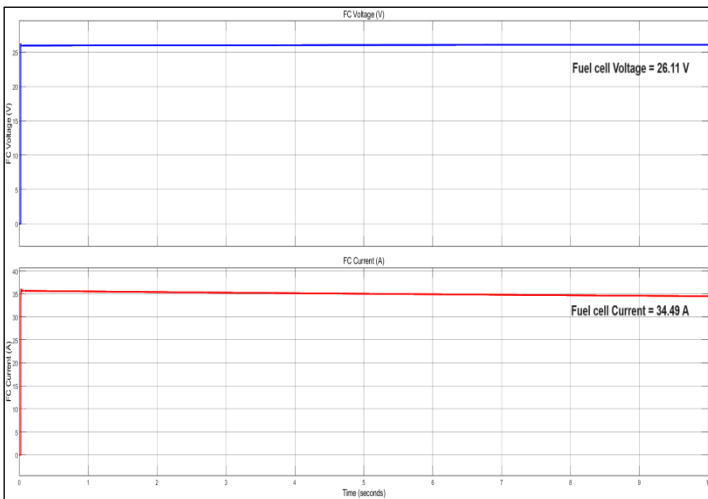

Figure 5: Characteristics response of open loop PEMFC based EV charging with SEPIC converter.
Source: Authors, (2024).

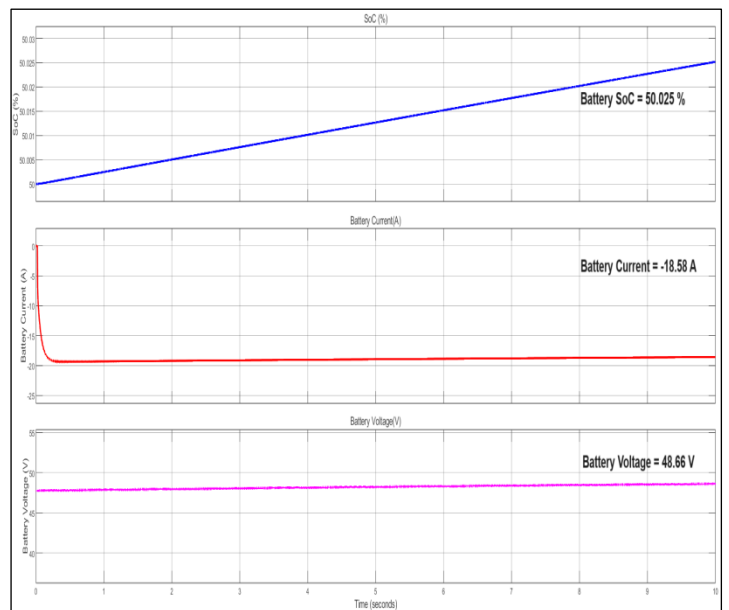

Figure 8: Battery charging results open loop PEMFC based EV charging with modified SEPIC converter.
Source: Authors, (2024).

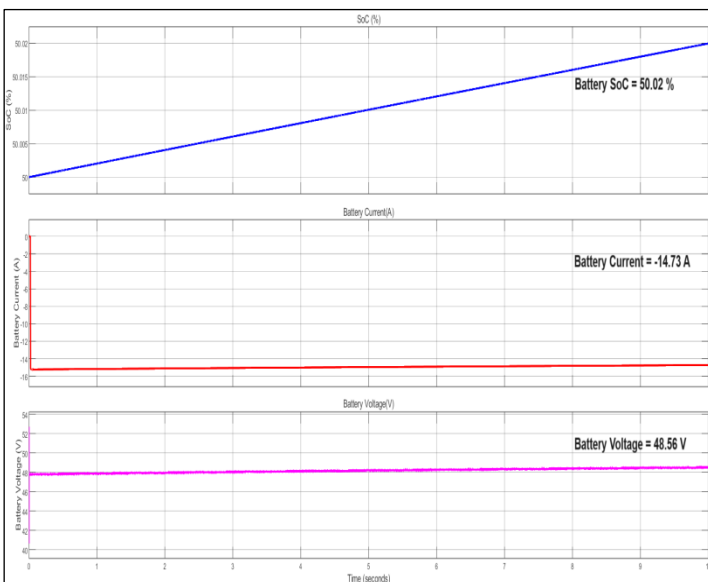

Figure 6: Battery charging results open loop PEMFC based EV charging with SEPIC converter.
Source: Authors, (2024).

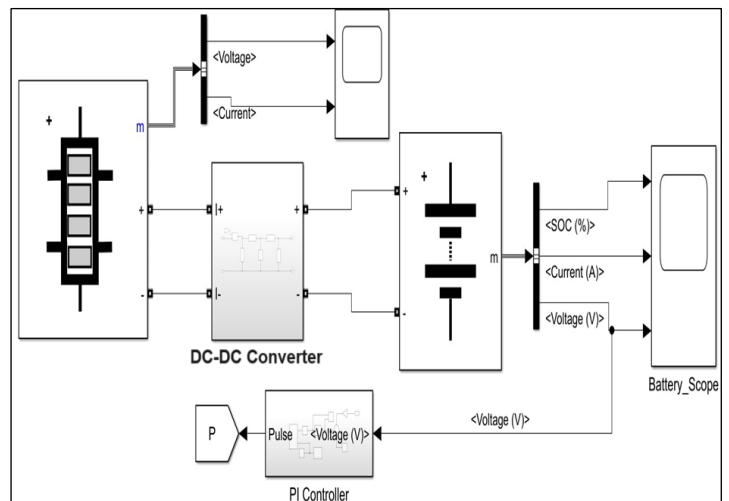

Figure 9: MATLAB/Simulink Model of closed loop fuel cell based EV charging system
Source: Authors, (2024).

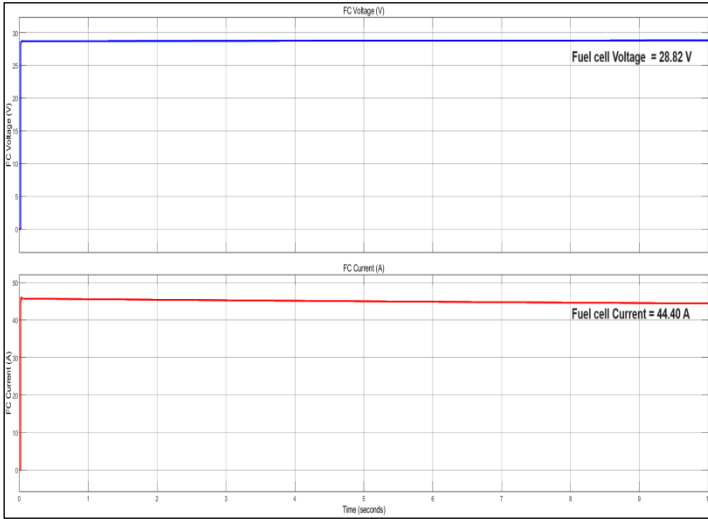

Figure 10: Characteristic response of closed loop PEMFC based EV charging system with ZETA Converter.
Source: Authors, (2024).

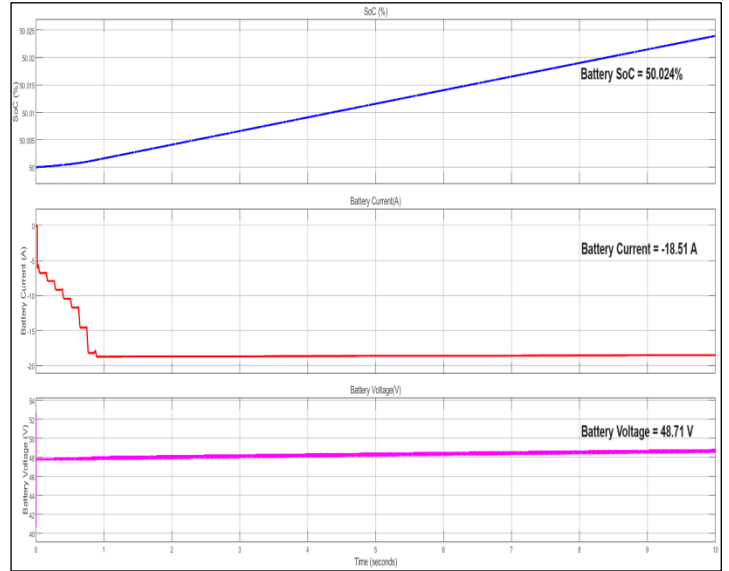

Figure 13: Battery charging results of closed loop PEMFC based EV charging system with SEPIC Converter.
Source: Authors, (2024).

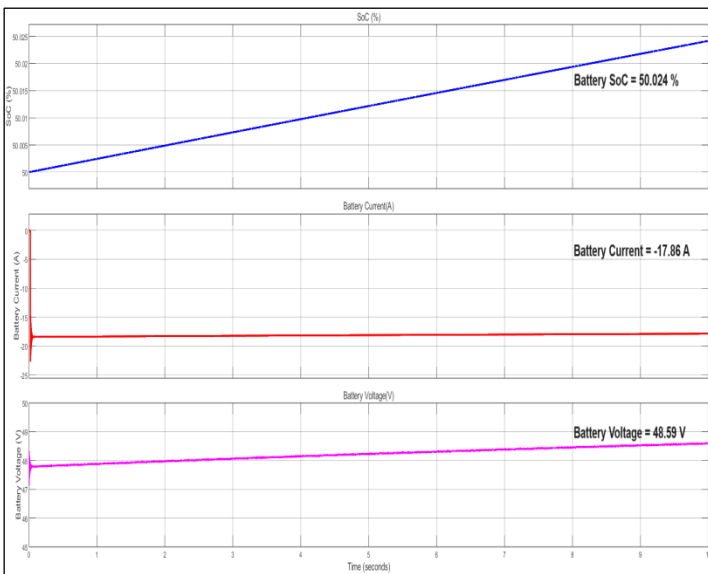

Figure 11: Battery charging results of closed loop PEMFC based EV charging system with ZETA Converter.
Source: Authors, (2024).

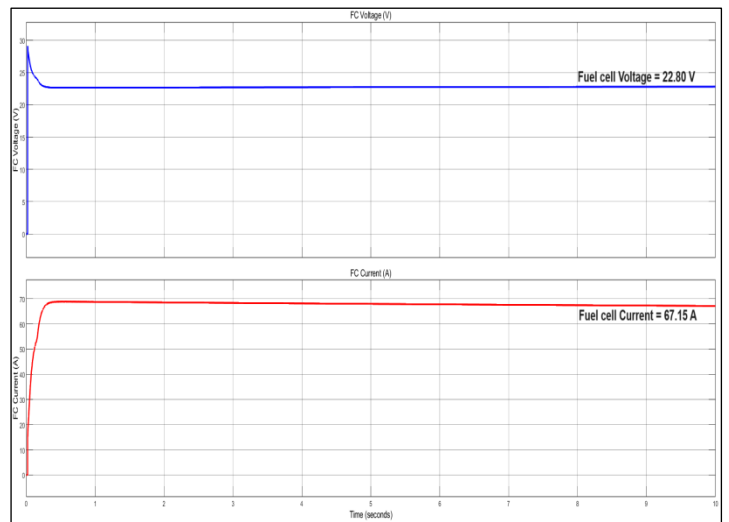

Figure 14: Characteristic response of closed loop PEMFC based EV charging system with modified SEPIC Converter.
Source: Authors, (2024).

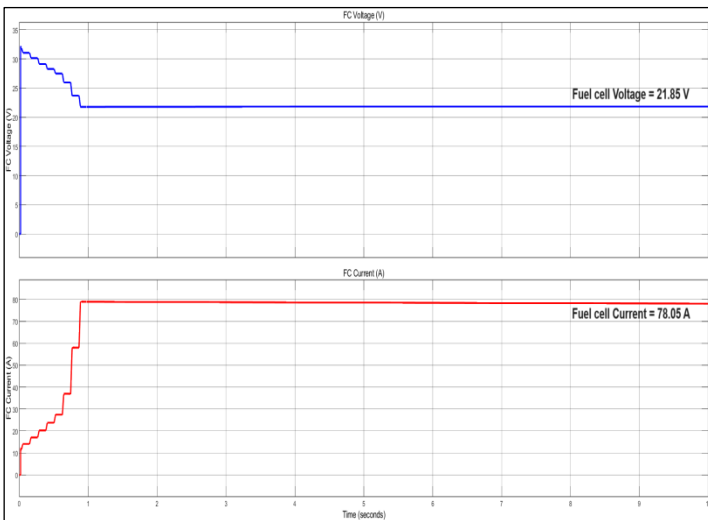

Figure 12: Characteristic response of closed loop PEMFC based EV charging system with SEPIC Converter.
Source: Authors, (2024).

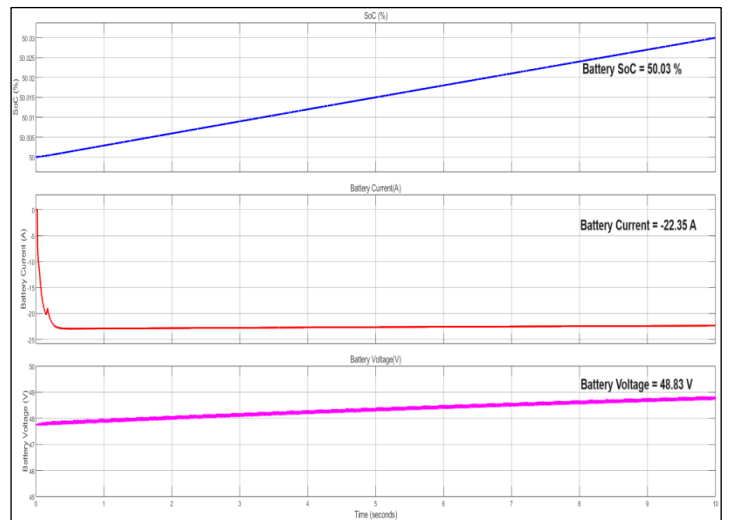

Figure 15: Battery charging results of closed loop PEMFC based EV charging system with modified SEPIC Converter.
Source: Authors, (2024).

The results of fuel cell powered EV charging system through Zeta, SEPIC and modified SEPIC converters under same test conditions with open loop and closed loop approaches are illustrated in the Table 4. The value of battery current is negative which denotes that the battery is in charging state.

Table 4: Simulation results with SoC of 50% for 10sec.

	Zeta Converter		SEPIC Converter		Modified SEPIC Converter	
	Open Loop	With PI	Open Loop	With PI	Open Loop	With PI
SoC (%)	50.024	50.024	50.02	50.024	50.025	50.03
V _b (V)	48.58	48.59	48.56	48.71	48.66	48.83
I _b (A)	-17.86	-17.86	-14.73	-18.51	-18.58	-22.35
V _{FC} (V)	28.82	28.82	26.11	21.85	25.11	22.80
I _{FC} (A)	44.40	44.40	34.49	78.05	43.41	67.15
Time (H)	5.47	5.47	6.56	5.47	5.33	4.37

Source: Authors, (2024).

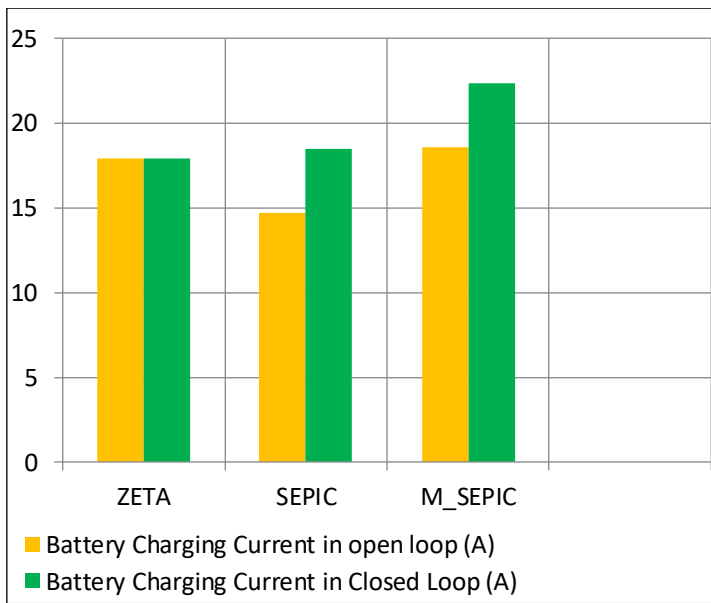

Figure 16: Pictorial representation of battery charging current from simulation results. Source: Authors, (2024).

V. CONCLUSIONS

A comparative performance analysis of fuel cell powered EV charging system using ZETA, SEPIC and Modified SEPIC converter topologies with open loop and closed loop techniques is simulated in MATLAB/ Simulink environment and the findings are evaluated. From the simulation findings, it is observed that the charging current delivered by modified SEPIC is more when compared to other converters, and thereby a swift increase in the battery’s state of charge. The time taken for charging a battery using the ZETA, SEPIC & modified SEPIC converters under open loop control is 5.47Hrs, 6.56Hrs & 5.33 Hrs respectively. With closed loop control, ZETA & SEPIC still requires 5.47Hrs while modified SEPIC requires 4.37Hrs. Therefore with fuel cell as primary energy source, the modified SEPIC converter outperforms other two converts in all aspects.

VI. AUTHOR’S CONTRIBUTION

Conceptualization: Bondu Pavan Kumar Reddy and Dr. Vyza Usha Reddy.

Methodology: Bondu Pavan Kumar Reddy and Dr. Vyza Usha Reddy.

Investigation: Bondu Pavan Kumar Reddy and Dr. Vyza Usha Reddy.

Discussion of results: Bondu Pavan Kumar Reddy and Dr. Vyza Usha Reddy.

Writing – Original Draft: Bondu Pavan Kumar Reddy and Dr. Vyza Usha Reddy.

Writing – Review and Editing: Bondu Pavan Kumar Reddy and Dr. Vyza Usha Reddy.

Resources: Bondu Pavan Kumar Reddy and Dr. Vyza Usha Reddy.

Supervision: Bondu Pavan Kumar Reddy and Dr. Vyza Usha Reddy.

Approval of the final text: Bondu Pavan Kumar Reddy and Dr. Vyza Usha Reddy.

VII. ACKNOWLEDGMENTS

The authors would like to express their sincere gratitude to Sri Venkateswara University College of Engineering for providing necessary guidance and support. We are also grateful to the anonymous reviewers for their constructive comments that helped us to improve the quality of this manuscript

VIII. REFERENCES

[1] Andreas Jossen, Juergen Garche, Harry Doering, Markus Goetz, Werner Knaupp and Ludwig Joerissen "Hybrid systems with lead–acid battery and proton-exchange membrane fuel cell", Journal of Power Sources, Volume 144, Issue 2, 2005, Pages 395-401, ISSN 0378-7753, <https://doi.org/10.1016/j.jpowsour.2004.11.010>

[2] Hossein Pourrahmani, Martin Gay and Jan Van herle, "Electric vehicle charging station using fuel cell technology: Two different scenarios and thermodynamic analysis", Energy Reports, Volume 7, 2021, Pages 6955-6972, ISSN 2352-4847, <https://doi.org/10.1016/j.egy.2021.09.211>

[3] R. -J. Wai, C. -Y. Lin, R. -Y. Duan and Y. -R. Chang, "High-Efficiency DC-DC Converter With High Voltage Gain and Reduced Switch Stress," in IEEE Transactions on Industrial Electronics, vol. 54, no. 1, pp. 354-364, Feb. 2007, DOI: <https://doi.org/10.1109/TIE.2006.888794>.

[4] Data sheet, Hanselng Technologies Ltd., Available online: <https://hanselng.com> (Accessed on 25 January 2023).

[5] B. Pavan kumar Reddy & V. Usha Reddy “PV-based performance evaluation of ZETA and SEPIC topologies for EV applications”, Journal of Electrical Systems, Volume 20 No5s, April 2024, Pp 438-446, ISSN: 1112-5209. DOI: <https://doi.org/10.52783/jes.2068>

[6] B. Pavan kumar Reddy & V. Usha Reddy “PV-Based Design and Evaluation of Power Electronic Topologies for EV Applications”, International Journal of Experimental Research and Review, Volume 39, May 2024, Pp 118-128, ISSN: 2455-4855. DOI: <https://doi.org/10.52756/ijerr.2024.v39spl.009>

[7] B. Pavan kumar Reddy & V. Usha Reddy “Design and Analysis of Novel Topology for PV-Fed EV Charging System”, Journal of Engineering and Technology for Industrial Applications, Volume 10, No 47, June 2024, Pp 109-114, ISSN: 2447-0228. DOI: <https://doi.org/10.5935/jetia.v10i47.1108>