

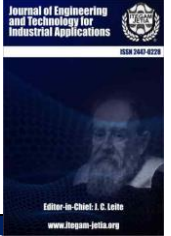

ISSN ONLINE: 2447-0228



OPEN ACCESS

RESEARCH ARTICLE

A RADIO FREQUENCY SYSTEM FOR SMART ATTENDANCE IN SCHOOLS

Akeem Abimbola Raji^{*1}, Joseph Folorunso Orimolade², Oluwaseun Ibrahim Adebisi³

¹ Department of Electrical and Electronics Engineering, Olabisi Onabanjo University, Ago-Iwoye, Ogun State Nigeria.

² Department of Electrical and Electronics Engineering, Afe Babalola University, Ado-Ekiti, Nigeria.

³ Department of Electrical and Electronics Engineering, Federal University of Agriculture, Abeokuta, Nigeria.

¹ <http://orcid.org/0000-0003-4303-4940> , ² <http://orcid.org/0000-0002-7655-3651> , ³ <http://orcid.org/0000-0001-8958-4951> 

Email: rajiakeemabimbola@gmail.com, orimoladejf@abuad.edu.ng, adebisoluwaseun@funaab.edu.ng.

ARTICLE INFO

Article History

Received: October 28, 2024

Revised: November 6, 2024

Accepted: November 10, 2024

Published: November 30, 2024

Keywords:

Attendance,
RFID tag,
RFID reader,
Node MCU,
Smart system

ABSTRACT

Attendance is necessary in schools for curbing staff and students absenteeism and lateness to classes. Traditional method of taking attendance where students write and sign on a sheet of paper is time consuming and labour intensive. This work presents smart attendance system that eases the way attendance is taken in lecture halls. The system integrates database with hardware components such as Radio Frequency Identification (RFID) card, RFID reader, I2C driver, display unit and Node Microcontroller Unit (NodeMCU) which has lower power consumption and better processing speed than Arduino microcontroller commonly used in the literature. Performance test conducted shows that the system performs its functions satisfactorily. The system reads and transfers students' data to the database in 3 seconds. In addition, students are asked to evaluate the performance of the system in terms of ease of use, functionality, efficiency, friendly user interface and speed of data transfer to the database. It is found that a good number of the students rate the ease of use, functionality, friendliness in the user interface and speed of data transfer excellent while more than average of the students rate the efficiency of the system good. The system is recommended for use in schools.



Copyright ©2024 by authors and Galileo Institute of Technology and Education of the Amazon (ITEGAM). This work is licensed under the Creative Commons Attribution International License (CC BY 4.0).

1. INTRODUCTION

Attendance is essential in schools and organizations for ensuring punctuality of students in classes and for preventing staff from lateness to work. Conventional methods of taking attendance include manual and swipe methods. Manual method involves students or staff writing and signing against his or her names on a sheet of paper. This approach can be easily manipulated as smart students or staff may impersonate and write on behalf of his or her colleagues making a mess of the method. The data generated from this approach cannot be relied upon and may be misleading. Though automated swipe card represents an upgrade on manual attendance where users swipe their cards on a system before gaining entry into the premises. The system can also be compromised to allow unauthorized access. In recent years, Radio Frequency Identification (RFID) technology is gaining wide usage in a number of applications including engineering construction [1-3], shopping malls and industries. The system utilizes RFID tag in line of sight with RFID reader for automatic detection and identification. The technology offers a number of advantages

including security, reduced size, diversity and enhanced efficiency [3].

Previous works in the literature that have adopted this approach for different purposes include [4] which constructed RFID based robot for picking and placing an object. Researchers in [5] developed door control system that allowed users with preregistered RFID tags to gain entrance into a building. A digital sliding gate was developed in [6], where ATMEG8a microcontroller was utilized to control the servo motor. The gate opened when the system recognized the RFID card brought before it and denied access to unrecognized users. Authors in [7] constructed RFID library management system for controlling access to the library and for identification of books. Employee attendance management system was implemented in [8], where RFID tag was placed at a distance of 2cm from RFID reader before the data of the employee could be verified. RFID wireless car security system was presented in [9] for preventing car theft. Authors in [10] developed RFID system for disseminating information such as lecture and exam schedules to students. A database to track lecturer attendance in classes was developed in

[11] where each lecturer was provided with near field communication (NFC) card which was read by NFC reader. Authors in [12] introduced RFID based student attendance management system that eliminated time wastage in manual collection of attendance while works of [13-14] constructed digital attendance management system using RFID technology and Arduino uno microcontroller. According to [15] designed a tele-monitoring attendance system consisting of RFID device and photo cells. While RFID architecture was used for identification of students, photo cells were used to detect fraud. Research works in [16],[17] presented a graphical user interface application for students' attendance.

Authors in [18] developed attendance management system consisting of RFID hardware and Microsoft visual basic application as database. According to [19] developed student identification system for checking and admitting students into the examination hall. Authors made use of Arduino microcontroller series for configuring the sytem.

This work develops a smart attendance system where radio frequency technology is used for taking attendance of students in classes. In particular, ESP8266 microcontroller is used for improving the speed of information transfer from the hardware to the database and for improving the efficiency of the system. The microcontroller has better processing speed and requires less power than Arduino microcontroller hitherto used in the literature.

II. MATERIAL AND METHODS

II.1 OVERVIEW OF THE SYSTEM

Figure 1 illustrates the block diagram of the proposed smart attendance system which shows the interaction between the hardware and software parts. The hardware includes power supply unit, RFID card, RFID card reader, Node Microrolller Unit (NodeMCU) and display unit while the software part includes the database. Each unit is described as follows.

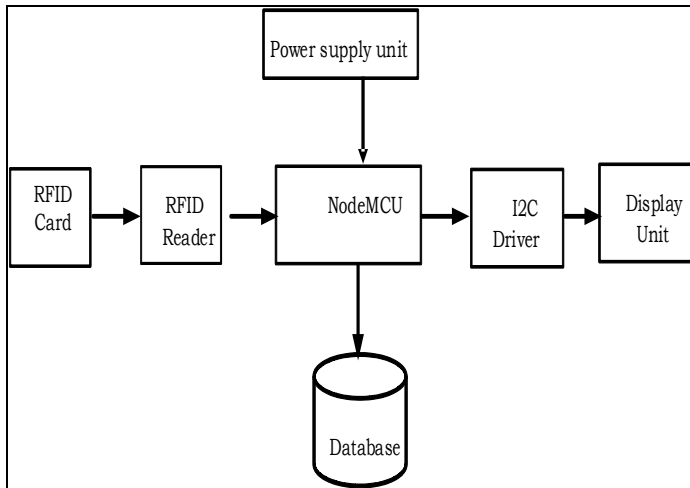

Figure 1: Block diagram of the proposed smart attendance system. Source: Authors, (2024).

II.2 POWER SUPPLY UNIT

The power supply provides the required voltage for proper functioning of the system hardware components. It ensures that NodeMCU, RFID reader and display unit receive stable and regulated power required for reliable operation. NodeMCU and RFID reader typically operate at 3.3V or 5V, while the display unit

requires a 5V supply. A 5V D.C battery from laptop or desktop is utilized to power the system.

II.3 RADIO FREQUENCY IDENTIFICATION (RFID) CARD

Radio Frequency Identification (RFID) cards contain a chip and an antenna. The chip stores a unique identification (UID) number and the antenna allows the card to communicate with the RFID reader. When an RFID card comes within the range of an RFID reader, the reader sends out a radio wave signal which is picked by the RFID card antenna. Figure 2 shows the RFID card.



Figure 2: RFID card. Source: [20].

II.4 RFID READER

RFID reader is utilized to detect and read RFID cards, extracting their UID number on the card. It reads the UID number and determines if it corresponds to a known student or a new card. For recognized cards, it records attendance by linking the UID to student data, such as name and matriculation number. Students' details are transmitted to the database through Wi-Fi using HTTP request, typically formatted in JavaScript Object Notation (JSON). It is an essential component for efficient attendance tracking, ensuring seamless communication between RFID cards and digital records in the database. Figure 3 illustrates the RC522 RFID card reader.

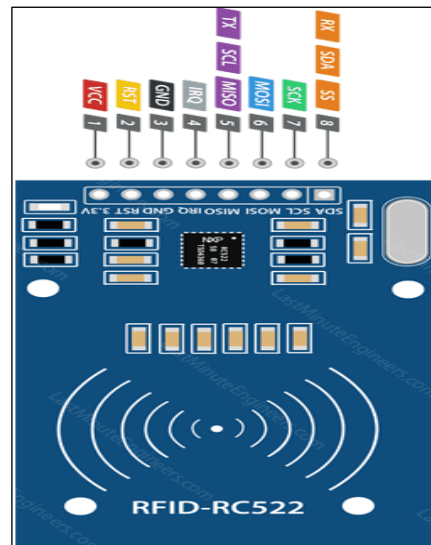

Figure 3: RC522 RFID Reader. Source: [21].

II.4 NODE MICROCONTROLLER UNIT (NODEMCU)

Node Microcontroller Unit (NodeMCU) is an open source Internet of Things (IoT) platform that consists of ESP8266 Wi-Fi chip. Its primary function encompasses wireless connectivity, data processing, RFID communication, data storage and transmission. It is used to coordinate the activity of the system by interacting with various hardware components to enable efficient attendance tracking and database communication. It processes data from the

RFID reader, manages display unit, and provides visual feedback. It connects to a local Wi-Fi network to facilitate communication with a database for data storage. Key pins associated with Wi-Fi connectivity in NodeMcU include transmitter (TX) and receiver (RX) pins. It communicates with the RFID reader using pins D8 (GPIO15) and D2 (GPIO4). Figure 4 illustrates the pin configuration of NodeMCU.

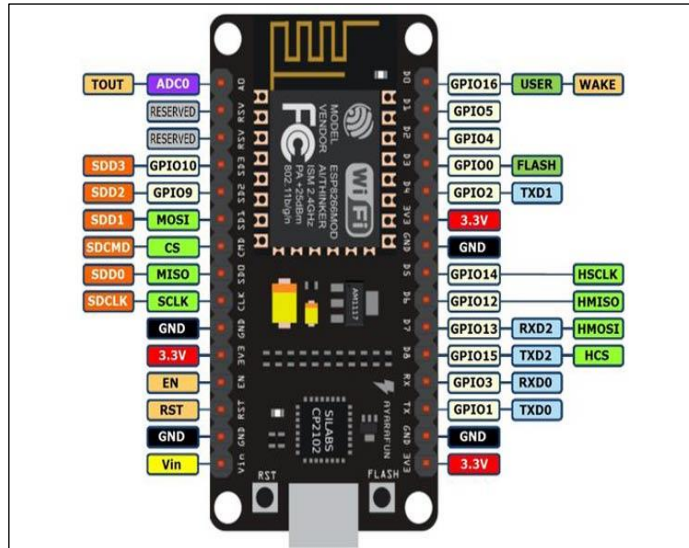

Figure 4: Pin configuration of NodeMCU.
Source: Authors, (2024).

II.6 DISPLAY UNIT

The Liquid Crystal Display (LCD) is used for providing a user-friendly interface for the smart attendance system. It is utilized for displaying important information to the users in real-time. It displays messages for successful scan and error messages when RFID cards are not scanned by RFID reader. In addition, it displays the activities of the the proposed smart attendance system at every point in time. It enhances the overall user experience by making the system more interactive and informative, facilitating efficient attendance tracking. Figure 5 shows the pin configuration of LCD.

II.7 I2C DRIVER

The I2C driver handles communication between NodeMCU and LCD making it easier to display text. Figure 6 shows the I2C driver.

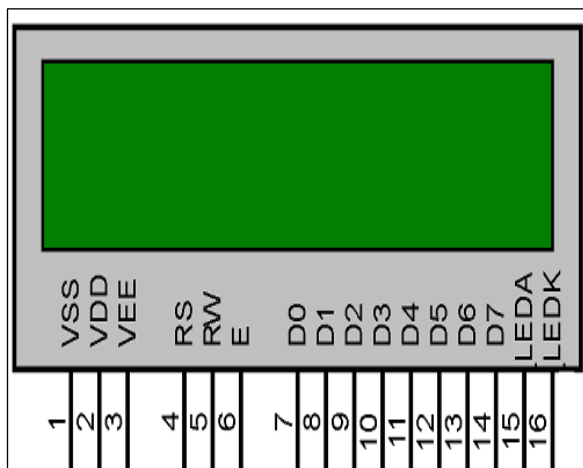

Figure 5: Pin configuration of 16X2 LCD.
Source: [22].

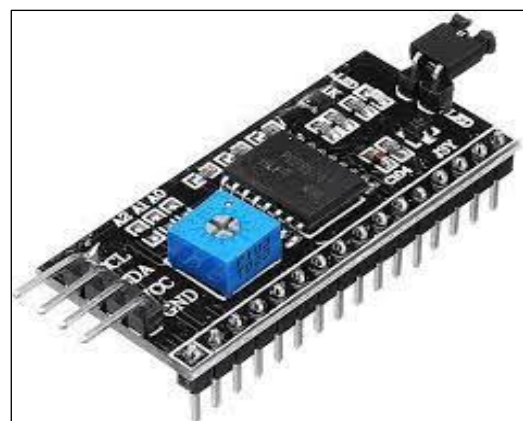

Figure 6: PCF 8574 I2C Driver
Source: Authors, (2024).

II.8 DATABASE

The database is used to store and keep the attendance of the students. Google spread sheet is utilized as database for keeping the students' attendance record.

The proposed smart attendance system is implemented using the the flow chart presented in Figure 7.

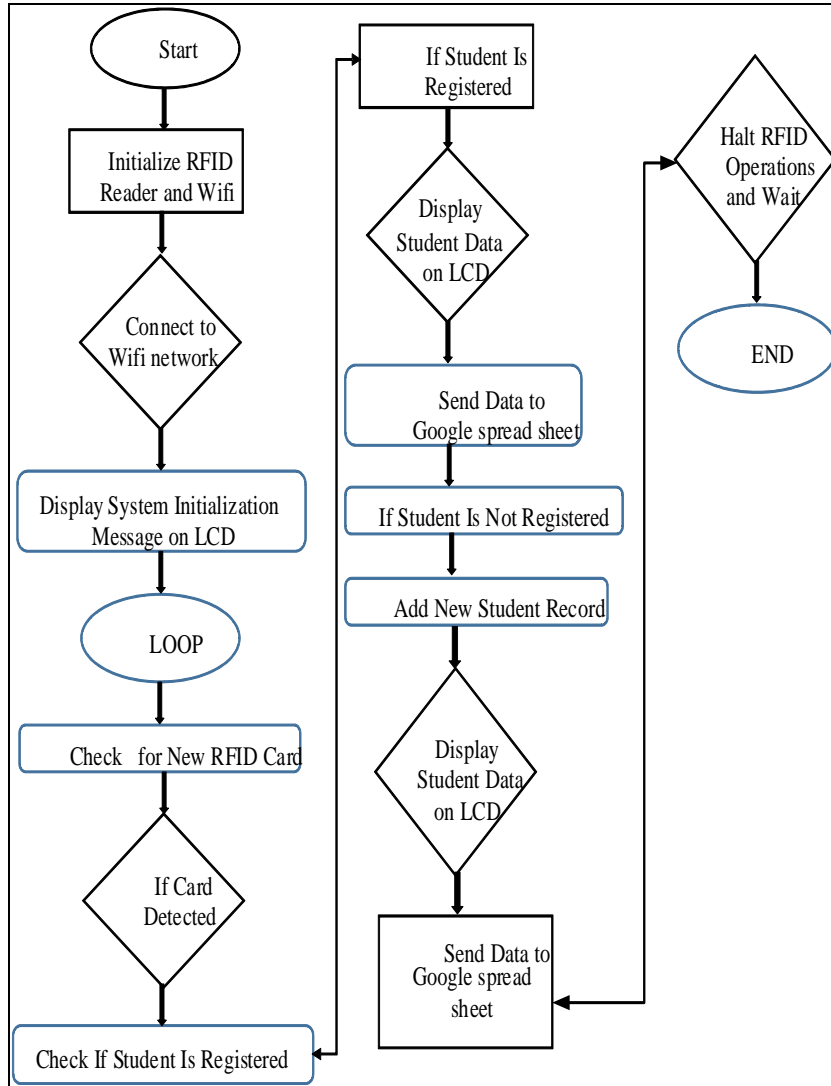

Figure 7: Flow chart of operation of the proposed RFID smarte attendance system.

Source: Authors, (2024).

II.8 DESIGN ALGORITHM OF THE PROPOSED SMART ATTENDANCE SYSTEM

The following algorithm highlights the steps taken in implementing the proposed smart attanance system which further explains the flow chart presented in Figure 7.

Algorithm: Operational sequence of wireless RFID system.

- Step 1: Initialize the RFID reader and Wi-Fi module.
- Step 2: Connect to the designated Wi-Fi network.
- Step 3: Display a system initialization message on the LCD.
- Step 4: Enter a continuous loop to monitor RFID card detection.
- Step 5: If a new RFID card is detected:
 - Check if the student is registered in the system
 - If registered
 - Display the student's data on the LCD.
 - Send attendance data to the Google spreadsheet
 - If not registered
 - Add a new student record
 - Display the student's data on the LCD

- Send attendance data to the Google spread sheet
- Halt RFID operations temporarily to avoid multiple scans for the same card
- Step 6: Repeat the loop
- End

III. RESULTS AND DISCUSSION

III.1 SMART ATTENDNACE SYSTEM DEVELOPMENT RESULT

Figure 8 illustrated the internal circuit connection of the proposed smart attendance system where RST pin of the RFID card reader was connected to D3 (Digital GPIO Pin) of NodeMCU while MISO, MOSI, SCK, and SDA pins of RFID reader were connected to D6, D7, D5, and D4 (Digital GPIO Pins) of NodeMCU. These connections ensured communication between NodeMCU and RFID module which facilitated the reading of RFID tags. In addition, SDA and SCL pins of LCD were connected to D2 and D1 (Digital GPIO Pins) of NodeMCU. For power supply considerations, the VCC pins of both RFID card reader and LCD were connected to 3.3 V output of NodeMCU while GND pins of these components were connected to the ground (GND) of

NodeMCU. This hardware setup was complemented by a Google spreadsheet which was used as database for storage and retrieval of students' attendance data.

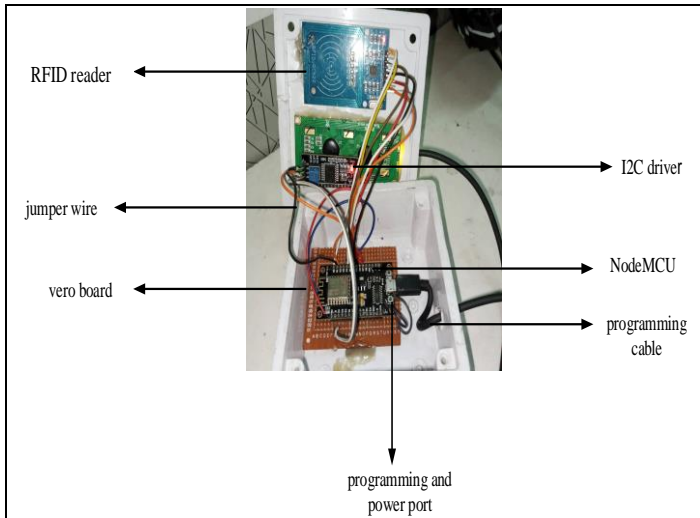

Figure 8: Internal components of the proposed smart attendance system.

Source: Authors, (2024).

III.2 PERFORMANCE EVALUATION RESULT

The proposed system was subjected to tests to verify and asses its performance. Figure 9a illustrated the proposed system connecting to Wi-Fi module on a laptop while Figure 9b depicted the snapshot of the prompt message which instructed the user to place the RFID card. Figure 10a illustrated the proposed system reading the information on RFID card while Figure 10b illustrated the transfer of the information on RFID card to Google spreadsheet. It was therefore seen that the system read RFID tag data successfully, constructed JSON payload, and utilized HTTP to communicate with Google sheet, displaying feedback on LCD screen.

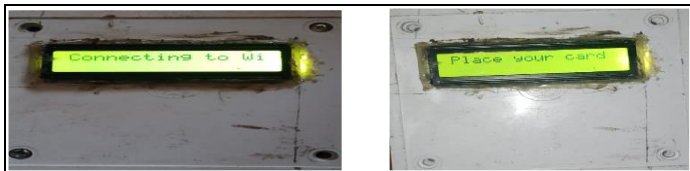

Figure 9: Proposed system under test, (a) system connecting to Wi-Fi module (b) system requesting for placement of card.

Source: Authors, (2024).

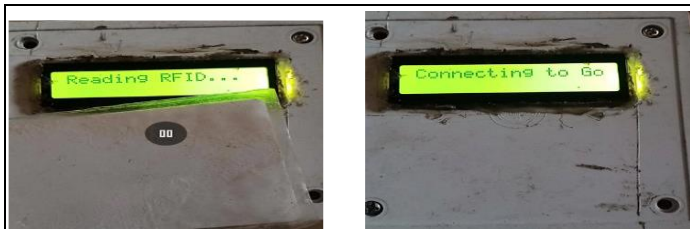

Figure 10: Proposed system under test (a) system reading the RFID card and (b) system directing the student details to the Google sheet.

Source: Authors, (2024).

Figure 11 presented the spreadsheet which revealed students's details such as the date of the class, time of the class,

matric number and names of the students, UID number as well as the address of the students in the class.

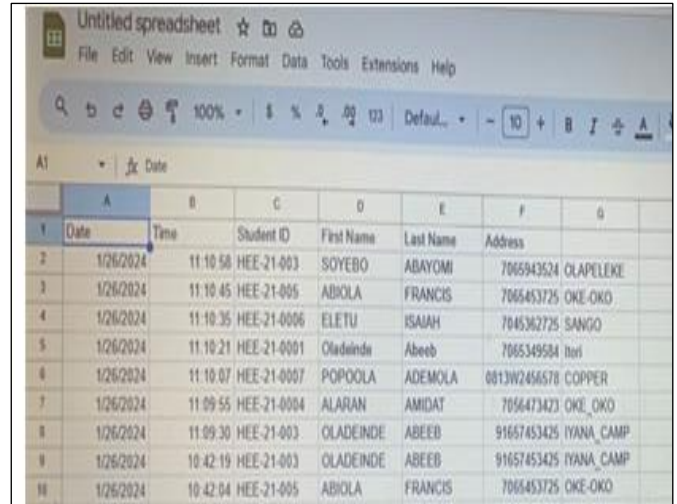

Figure 11: Snapshot of students' attendance.

Source: Authors, (2024).

A closer look of Figure 11 demonstrated the system's functionality which pointed to the fact that there existed synchronization and effective communication between hardware and software parts. This further implied that Google script in the spreadsheet communicated successfully with the NodeMCU, enabling real-time attendance taking and data transfer between the system and the spreadsheet. It was seen also that the Google App. script embedded in the spreadsheet, processed HTTP POST requests and updated the spreadsheet as more data were received. It was found that it only took 3s for the system to read and store information of students present in a class.

Furthermore, the students were tasked to assess the proposed system in terms of ease of use, efficiency, functionality, user interface friendliness and speed of data transfer to the database. The criteria and rating presented in Table 1 were used to assess the performance of the system. Table 2 therefore presented the summary of qualitative assessment of the system.

Table 1. Rating criteria for assessing the system

| Criteria | Excellent | Good | Average | Bad | Poor |
|----------|-----------|------|---------|-----|------|
| Rating | 5 | 4 | 3 | 2 | 1 |

Source: Authors, (2024).

Table 2: Summary of qualitative assessment of the system by the students

| Criteria | Excellent | Good | Average | Bad | Poor |
|--|-----------|------|---------|-----|------|
| Ease of use | 5 | 2 | 0 | 0 | 0 |
| Functionality | 4 | 3 | 0 | 0 | 0 |
| Friendliness in user interface | 5 | 1 | 1 | 0 | 0 |
| Ffficiency | 3 | 4 | 0 | 0 | 0 |
| Speed of data transfer to the database | 6 | 1 | 0 | 0 | 0 |

Source: Authors, (2024).

Using table 2, Figures 12-16 presented the percentage distribution of the scores of the assessment of the proposed system by the students.

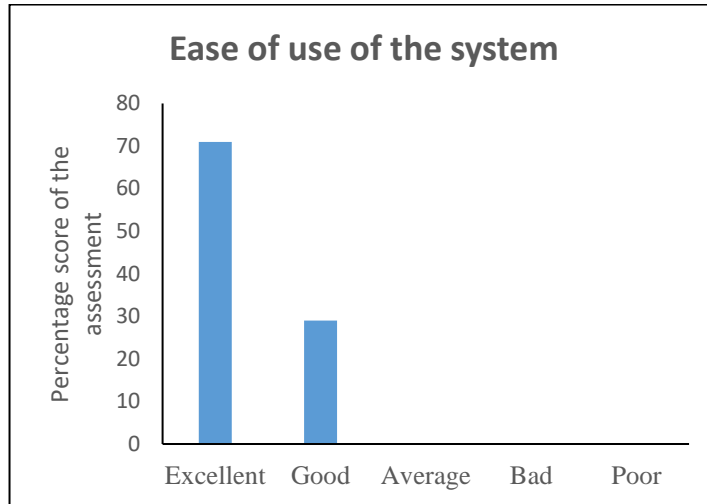

Figure 12: Result of the asseement of ease of use of the proposed system.
Source: Authors, (2024).

It was seen in Figure 12 that 71% of the students rated the ease of use of the system excellent while 29% rated it good. It was also observed that average, bad and poor ratings of the proposed system had no scores.



Figure 13: Result of the asseement of functionality of the system.
Source: Authors, (2024).

It was observed from Figure 13 that 57% of the students rated the functionality of the system excellent while 43% rated it good. No score was however recorded for average, bad and poor ratings.

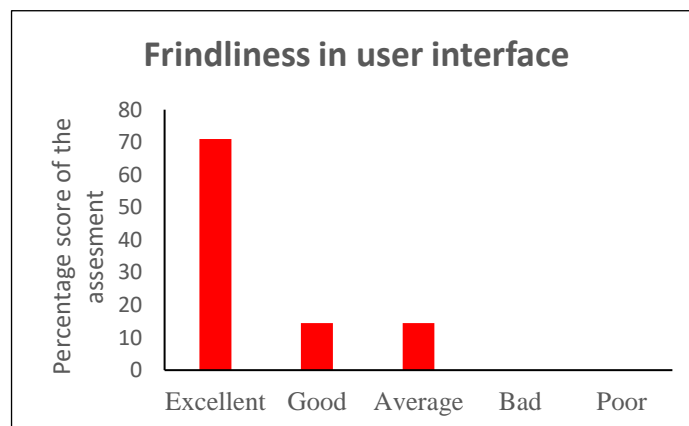

Figure 14: Result of the asseement of user interface friendliness
Source: Authors, (2024).

In terms of friendliness in the user interface of the proposed system, Figure 14 showed that 71% rated the system excellent while 14.5% and 14.5% rated the system good and average, respectively. It was seen also that bad and poor criteria had no score.



Figure 15: Result of the asseement of efficiency of the system.
Source: Authors, (2024).

Figure 15 showed that 43% of the students rated the efficiency of the system excellent, 57% rated it good while no student rated the system average, bad and poor.

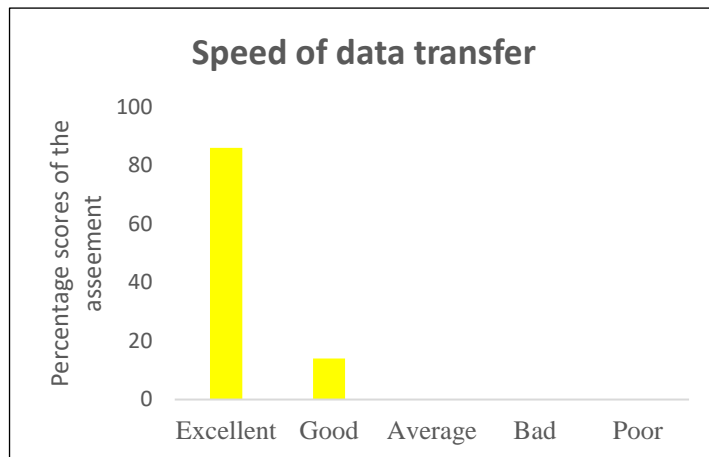

Figure 16: Result of the asseement of speed of data transfer of the system.
Source: Authors, (2024).

It was observed in Figure 16 that 86% of the students rated the speed of data transfer to the database excellent while 14% rated it good. Average, bad and poor ratings of the system had no scores.

Furthermore, the present work was compared with a few of existing works in the literature in terms of features such as

connectivity, speed of information transfer, technology used, microcontroller used, power consumption and database. Table 3 presented the outcome of this comparison.

Table 3: Result of the comparison of the present work with previous works existing in the literature.

| Characteristics features | Reference [12] | Reference [13] | Reference [14] | Reference [17] | Proposed work |
|-------------------------------|----------------|----------------|----------------|----------------|--------------------|
| Technology | RFID | RFID | RFID | RFID | RFID |
| Connectivity | Blue tooth | Blue tooth | Blue tooth | Blue tooth | Wi-Fi or IEE802.11 |
| Speed of information transfer | Slow | Slow | Slow | Slow | Fast |
| Microcontroller used | Arduino | Arduino | Arduino | Arduino | NodeMCU (ESP8266) |
| database | Yes | No | No | Yes | Yes |
| Power consumption | Medium | Medium | Medium | Medium | low |

Source: Authors, (2024).

It could be seen from Table 3 that the proposed work improved on the existing work in terms of the use of ESP8266 microcontroller which made the sytem to consume less power and enhanced the rate at which information was sent to the database.

IV. CONCLUSIONS

This work proposed a smart system based on radio frequency technology for taking attendance of students in a class. The system

consisted of ESP8266 (Node Microcontroller Unit) for coordinating the activities of RFID reader, RFID card, I2C driver, display unit and database. The implementation of the overall system allowed students attendance to be taken and stored on Google spread sheet in a fast and efficient manner. The average time for the system to read RFID card and transfer students' details to the Google spreadsheet was 3s. In additon, the performance of the system was assessed by the students based on the criteria such as ease of use of the system, functionality,

friendliness in user interface, efficiency and speed of data transfer to the database. Results of the qualitative evaluation revealed that 71% of the students rated the ease of use of the system excellent while 29% rated it good. 57% and 43% of the students rated the functionality of the system excellent and good, respectively while 71%, 14.5%, and 14.5% rated the user interface excellent, good and average respectively. The efficiency of the system received 43% excellent and 57% good from the students. Moreover, 86% and 14% of the students rated the speed of transfer of data to the database excellent and good, respectively. The system is recommended for use in schools and business outlets for taking the attendance of students and workers.

V. AUTHOR'S CONTRIBUTION

Conceptualization: Akeem Abimbola Raji
Methodology: Akeem Abimbola Raji, Joseph Folorunso Orimolade, Oluwaseun Ibrahim Adebisi
Investigation: Akeem Abimbola Raji, Joseph Folorunso Orimolade, Oluwaseun Ibrahim Adebisi
Discussion of results: Akeem Abimbola Raji, Joseph Folorunso Orimolade, Oluwaseun Ibrahim Adebisi
Writing – Original Draft: Akeem Abimbola Raji
Writing – Review and Editing: Joseph Folorunso Orimolade, Oluwaseun Ibrahim Adebisi
Resources: Akeem Abimbola Raji, Joseph Folorunso Orimolade, Oluwaseun Ibrahim Adebisi
Supervision: Akeem Abimbola Raji, Joseph Folorunso Orimolade, Oluwaseun Ibrahim Adebisi
Approval of the final text: Akeem Abimbola Raji, Joseph Folorunso Orimolade, Oluwaseun Ibrahim Adebisi

VI. ACKNOWLEDGMENTS

The authors are grateful to the several authors whose works formed the basis for the present work.

VII. REFERENCES

- [1] C. Kim, Y. Ju and J-H Kim. "Resource management in civil construction using RFID technology", Proceedings of 26th International Symposium on Automation and Robotics in Construction, pp. 105-108, 2009.
- [2] P. Patil and A. Shelake. "An application of RFID technology to improve material management in construction sites", International Research Journal of Engineering and Technology, vol. 8, no. 2, pp. 1000-1003, 2021.
- [3] L-C Wang, Y-C Lim and P.H. Lim. "Mobile construction RFID-based supply chain management portal system." Joint International Conference on Computing and Decision making in Civil and Building Engineering, June 14-16, Montreal, pp. 2751-2761, 2006.
- [4] P. Kumari, L. Mathew and N. Kumar, "Combining Bio signals with RFID to develop a multimodal-shared control interface", Journal of Engineering and Applied Science, vol. 70, no. 119, pp. 1-15, 2022.
- [5] S.M.R. Rasid, F. Rashid, A-H Sabri and Rakibul Islam, "Design and construction of automatic security system of a door using RFID technology", International Journal of Scientific & Engineering Research, vol. 9, no. 9, pp. 1067-1073, 2018.
- [6] A.M. Adebimpe, D. Chukunbikpe, D. Uguru-Okorie and D.V. Arise, "Design and Implementation of a digital sliding gate using RFID technology", Fuoye Journal of Engineering and Technology, vol. 7, no. 1, pp. 53-56, 2022.
- [7] E.O. Edwards and P.E. Orukpe, "Development of a RFID based Library management system and user access control", Nigerian Journal of Technology (NIJOTECH), vol. 3, no. 4, pp. 574-584, 2014.
- [8] G.D.P Maramis and P.T.D Rompas, "Radio frequency identification (RFID) based management system", IoP Conf. Series: Materials Science and Engineering, 2018. Doi: 10.1088/1757-899x/306/11012045.
- [9] A.S. Hassan and M.A Saleh, "Design and construction of RFID wireless car security system", International Journal of Scientific Engineering and Science, vol. 1, no. 6, pp. 61-65, 2017.
- [10] Sambo et al, "An RFID-based student information system", Proceedings of 2017 IEEE 3rd International Conference on Electro-Technology for National Development, pp. 477-482, 2017.
- [11] G.S.E. Putra, A. Lee I.M.T. Mahayara and I.G.A.W Dharmayasa, "Design and development of lecturer attendance system using Radio Frequency Identification", International Journal of Computer Science Engineering, vol. 10, no. 1, pp. 15-27, 2021.
- [12] O.T. Arulogun, A. Olatunbosun, O.A. Fakolujo and O.M. Olaniyi, "RFID-based students attendance", International Journal of Scientific & Engineering Research, vol. 4, no. 2, pp. 1-9, 2013.
- [13] A.C. Ohajianya, V.N. Ebomuche, C.E. Agbo, and G.A. Ikeh, "Design and Development of a Radio Frequency Identification (RFID) based digital attendance system with master's E-identity card controlled access to the attendance taking mode", ARPN Journal of Engineering and Applied Sciences, vol. 15, no. 20, pp. 2210-2219, 2020.
- [14] O.C. Peter, O.L. Uwakwe, and C.C. Okoli, "Implementation of an RFID technology based digital class attendance system for university students", Journal of Emerging Trends in Engineering and Applied Sciences (JETEAS), vol. 13, no. 5, pp. 199-207, 2022.
- [15] M.A.H. Ali, and N.A. Yusoff, "Development of Tele-monitoring Attendance System using RFID and photo-cell", Proceedings of 2018 IEEE International Conference on Automatic Control and Intelligent Systems, pp. 83-88, 2018.
- [16] M. Kassim, H. Mazlan, N. Zaini and M.K. Salleh, "Web-based student attendance system using RFID technology", Proceedings of 2012 IEEE Control and System Research Colloquium (ICSGRC), pp. 213-218, 2012.
- [17] A.A.Olanipekun and O.K. Boyinbode, "A RFID based Automatic Attendance System in Educational Institutions in Nigeria", International Journal of Smart Home, vol. 9, no. 12, pp.65-74, 2015
- [18] T.C. Adeniran, Y. Sanni, N. Faruk, and A. Olawoyin, "Design and Implementation of an Automated Attendance Monitoring System for a Nigerian University using RFID", Africa J. Comp.& I.C.T. vol. 12, no. 2, pp. 72-89, 2019.
- [19] A. Oyedeji, I. Okakwu, and O. Abolade, "Development of an enhanced student identification system", Firat University Journal of Experimental and Computational Engineering, vol. 2, no. 2, pp.80-86, 2024.
- [20] S. Subashchandrabon and M. Pajany, "Hybrid of Student Attendance Tracking System using RFID Device and Finger Print Sensor", International Journal of Computer Science and Mobile Computing, vol. 4, no. 3, 271-278, 2015.
- [21] S.H.V.K. Ashok, N.D. Divya, F. Samuel, U. Mande, "RFID Based Attendance System" International Journal for Research in Applied Science & Engineering Technology", pp. 2239-2248, 2022.
- [22] A.I. Aniebiet and M. AbdulKadir, "Design and Construction of an RFID based Automatic Attendance Management System" International Journal of Scientific & Engineering Research, vol. 11, no. 12, pp. 1223-1264, 2020.