



FAULT PROTECTION ANALYSIS OF A DC MICROGRID USING VSC BASED MODULAR MULTILEVEL CONVERTER (MMC)

Kanna Sravanthi*¹ and Ayya Chaithanya²

^{1,2}Department of Electrical and Engineering, SV University, Tirupati, India.

¹<https://orcid.org/0009-0000-5910-7169>, ²<https://orcid.org/0009-0004-7501-210X>

Email: *sravanthikanna7@gmail.com, chaithu.maruthi@gmail.com

ARTICLE INFO

Article History

Received: October 17, 2025

Revised: November 20, 2025

Accepted: January 1, 2026

Published: January 31, 2026

Keywords:

AC Microgrid,
DC Microgrid,
PV System,
Voltage Source Converter,
Modular Multilevel Converter,
Differential Relay

ABSTRACT

DC microgrid development is increasing mainly due to its simplicity of operation and greater focus on renewable energy sources like solar, wind, etc. It comprises less losses than AC microgrid and can easily connect and disconnect distributed generation (DG). Conventional techniques of DC microgrid protection is challenging. Using MATLAB Simulink, a DC microgrid with a PV system, battery, and AC main grid along with converters including boost, buck, and voltage source/modular multilevel converters is simulated. This study compares the performance of modular multilevel converters and voltage source converters, as well as the way they protect DC microgrid in the case of an AC main grid fault condition. Additionally, for improved fault clearing response in overcurrent situations, the differential relay is used on the AC main grid, nearer to the transformer.



Copyright ©2026 by authors and Galileo Institute of Technology and Education of the Amazon (ITEGAM). This work is licensed under the Creative Commons Attribution International License (CC BY 4.0).

I. INTRODUCTION

Nowadays, grid integration and renewable energy sources are the primary areas of research study. Due to fossil fuels are becoming extinct and their emissions affect the environment, the usage of renewable energy sources has been growing. Decentralized generation (DG) is connected using both island/isolated and grid-connected techniques [1]. The grid-connected state has significant advantages over the island state. In grid-connected state, the grid provides power to the load is able to meet its demand in the event that there is any problem with the decentralized generation (DG). Depending on the type of system, converters including inverters, rectifiers, and filters are required for connecting decentralized generation (DG) to the grid. An extensive collection of decentralized generation systems is called a microgrid [2]. Compared to AC microgrids, DC microgrids are more effective, like the absence of reactive power and synchronization problems [3], [4]. DC microgrids have greater power transfer capabilities [5]. A DC microgrid's power flow is more robust due to multiple sources can connect to a single bus [6].

To integrate a AC main grid with the DC microgrid, a converter is required. These include multilevel converters, voltage source converters (VSC) and current source converters (CSC) [7]. Multilevel converters are utilized for large power applications, while voltage source converters operate efficiently for small and medium power applications. Current source converters (CSC's) need external AC capacitors for reactive power compensation and required forced or line commutation. VSCs are the most compatible and widely used topologies. But due to its complex construction and lack of adaptability when extending the voltage or power range, VSC is not suitable for high power applications. For high power applications modular multilevel converter is used. Capacitors and at the DC bus, additional passive filters are not necessary with MMCs, which is an advantage [8]. For DC Microgrid protection, the differential overcurrent relay is used near to the transformer for precise fault detection [9].

II. FAULT PROTECTION ANALYSIS

On a microgrid, the current direction changed whenever a fault occurred [10]. Circuit breakers receive the signal from relays and turn off the system that is out of fault. The DC Microgrid current direction before and after the fault develops as shown in the diagram below [11], [12].

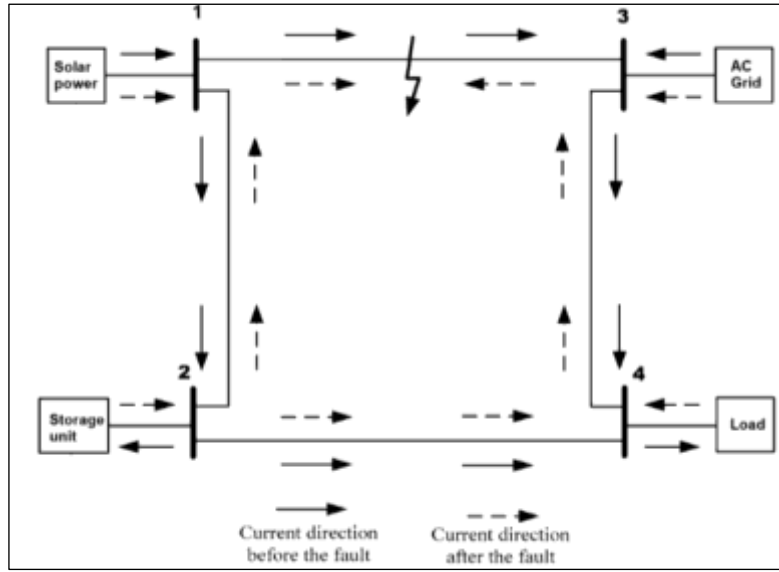

Figure 1: Before and after fault DC Microgrid current direction. Source: Authors, (2026).

The VSC and MMC act as switch between the AC main and the DC microgrid, as shown below [9].

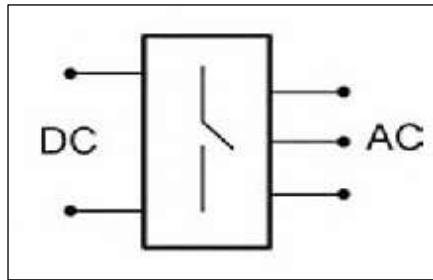

Figure 2: VSC/MMC acts as switch between DC and AC system. Source: Authors, (2026).

The circuit design for the MMC and VSC are shown below. Capacitors are present in the Modular Multilevel Converter's (MMC) sub module block. In order to safeguard the DC Microgrid against faults, the MMC does not require any external large capacitors [13-15].

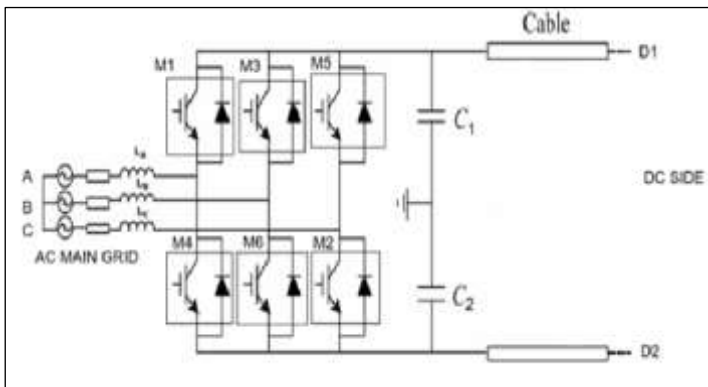

Figure 3: VSC circuit diagram.

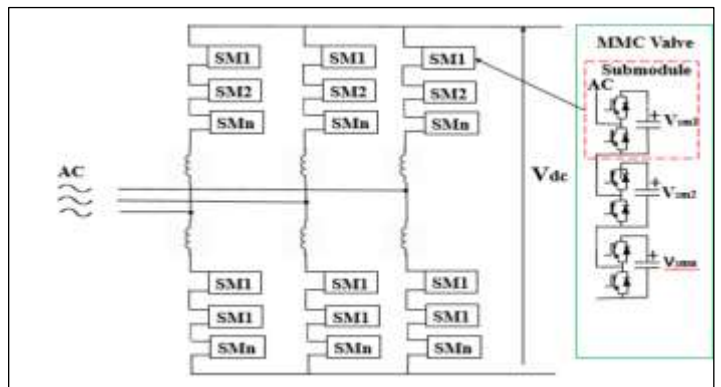

Figure 4: MMC circuit diagram.

Source: Authors, (2026).

The three cases below shows the fault that occurred on the DC side. The condition before the fault occurred was t_0 . At this point, the cable current is zero and the capacitor reaches its full charge. At t_0 , the fault occurred, the cable current is gradually increasing, and the capacitor's stored charge is gradually decreasing. When the capacitor's stored charge reaches zero at t_1 , the grid gradually begins feeding. The charging of the capacitor starts at t_2 [16].

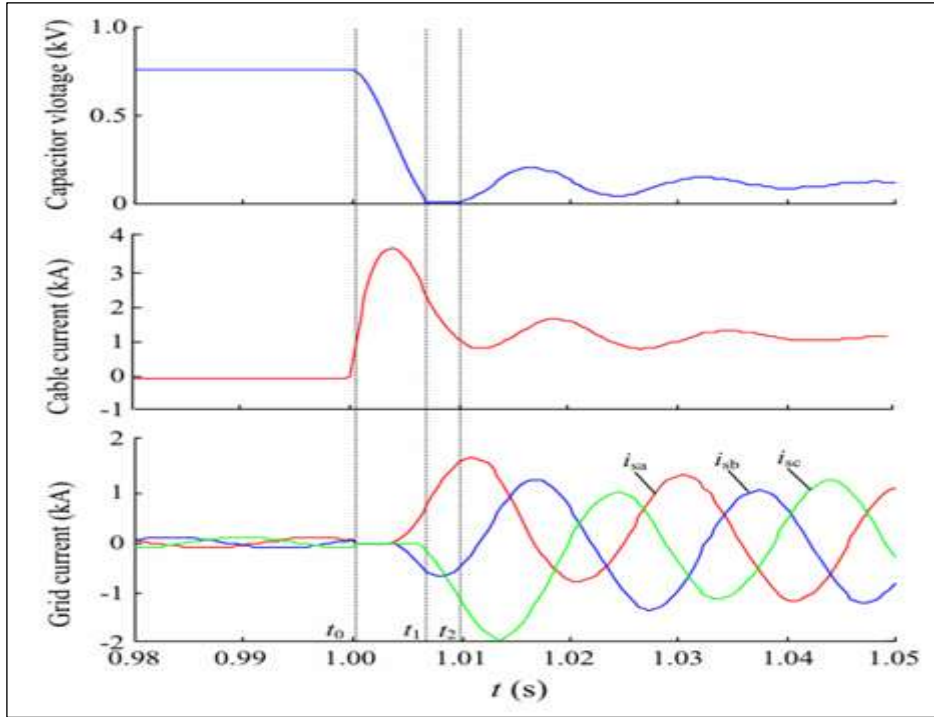

Figure 5: Fault characteristics.
Source: Authors, (2026).

III. SIMULATION

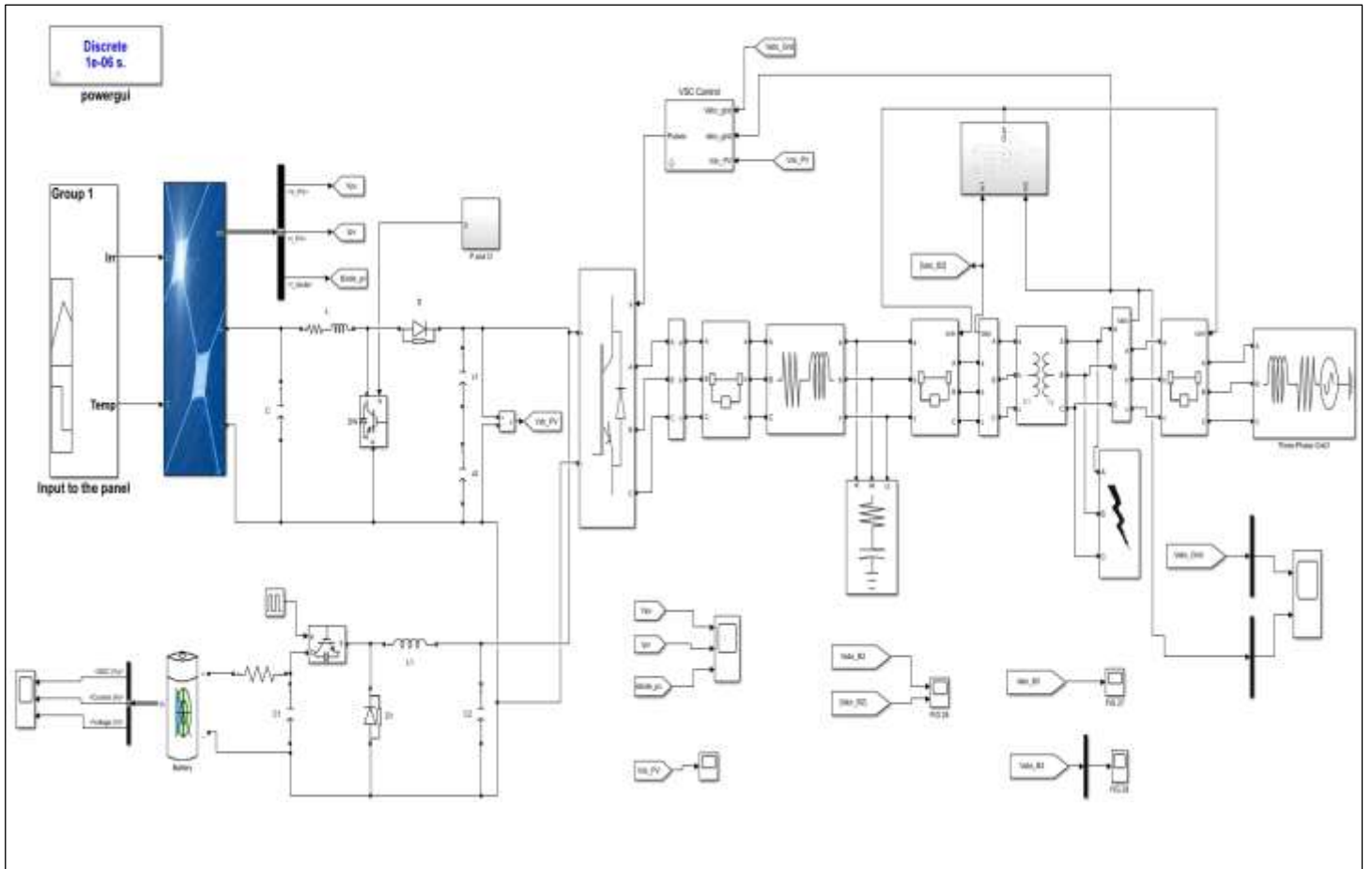

Figure 6: Simulink design of DC Microgrid and AC Main Grid with Voltage Source Converter (VSC).
Source: Authors, (2026).

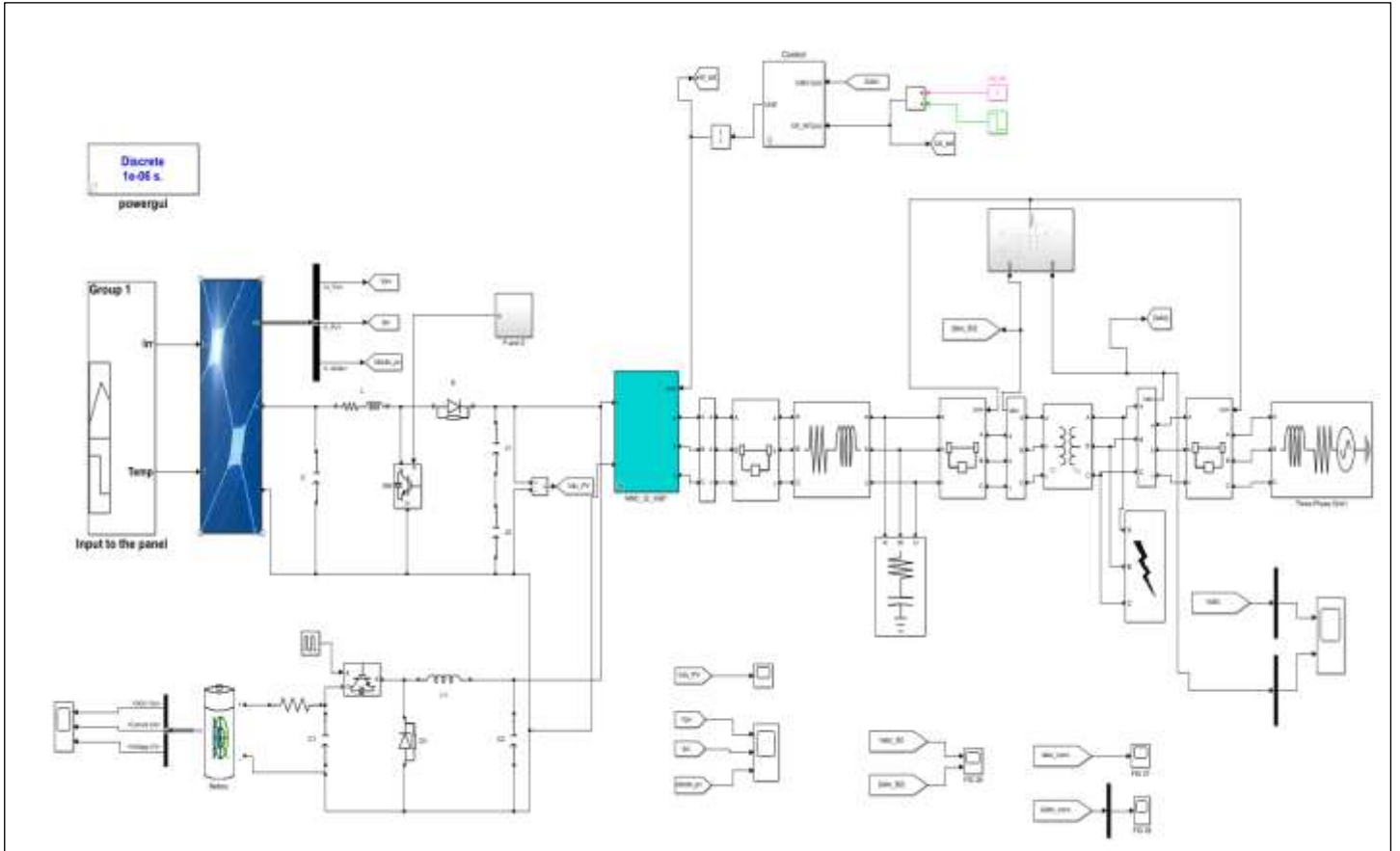

Figure 7: Simulink design of DC Microgrid and AC Main Grid with 32 IGBT Modular Multilevel Converter (MMC).
Source: Authors, (2026).

Table 1: AC Main Grid specifications.

S.No	Name of parameters	Value
1	Phase to phase voltage (V_{rms}) of three-phase Grid	25 KV
2	Nominal power of three-phase transformer	100 KVA
3	Active power of three phase series RLC load	10 KW
4	Nominal phase to phase voltage (V_{rms})	440 V

Source: Authors, (2026).

IV. RESULTS AND DISCUSSIONS

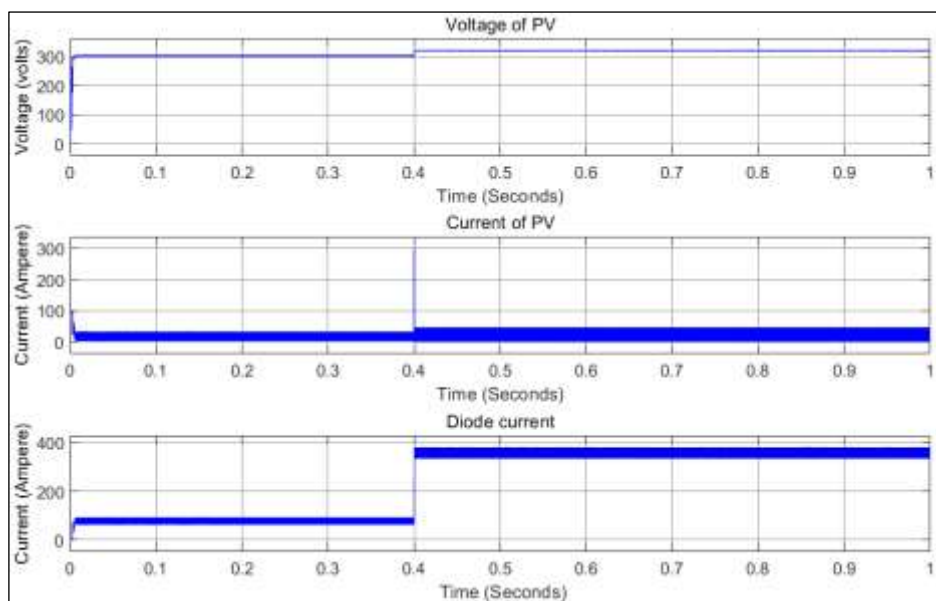

Figure 8: Voltage, current and diode current of PV system.
Source: Authors, (2026).

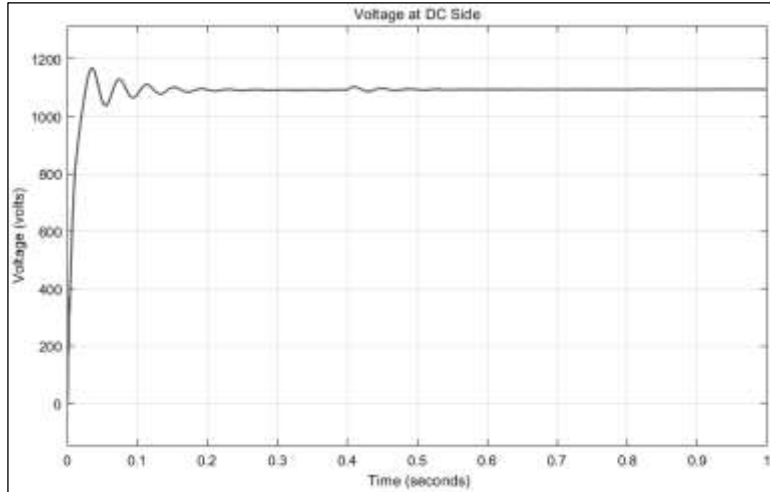

Figure 9: Output voltage of DC Microgrid.
Source: Authors, (2026).

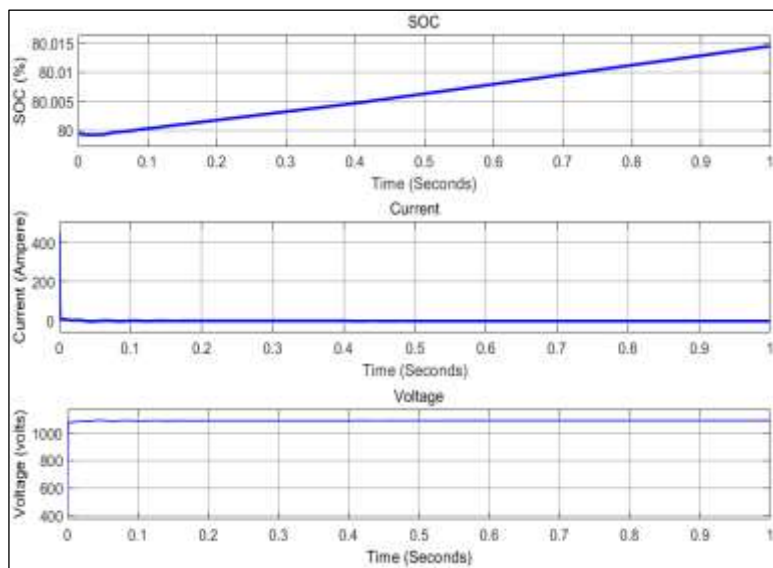

Figure 10: Battery parameters.
Source: Authors, (2026).

The figures mentioned above display the voltage, current, and diode current of the PV system. A DC microgrid's output voltage is 1.169KV. Lithium-ion battery parameters are displayed.

IV.1 FAULT CONDITION (LLLG) OF VSC

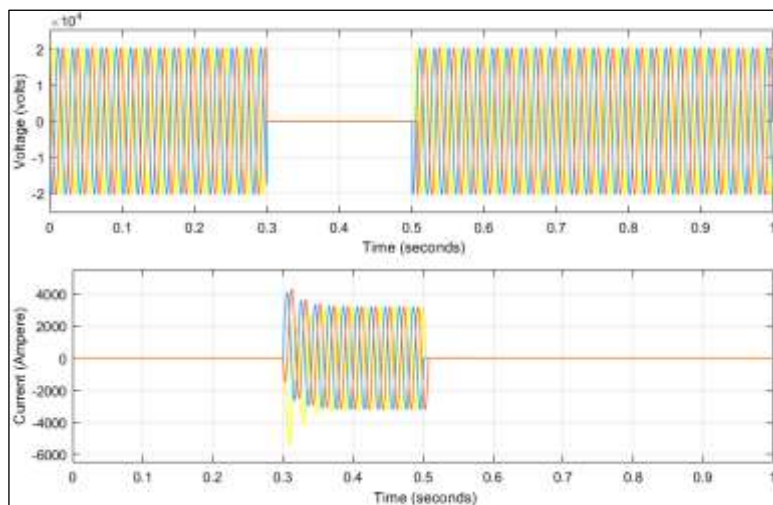

Figure 11: Voltage and current of AC Main Grid by using VSC.
Source: Authors, (2026).

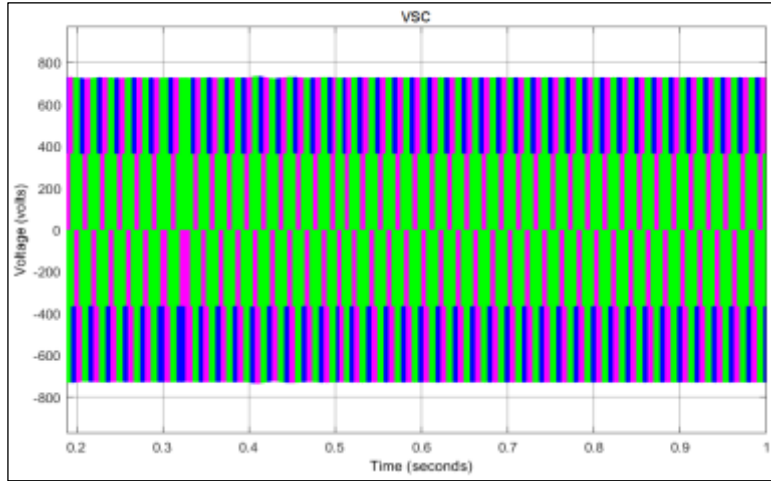

Figure 12: Voltage of VSC.
Source: Authors, (2026).

The LLLG fault is applied between 0.3 and 0.5 seconds on the AC Main Grid. Variations in AC Main Grid voltage and current are noted before to, during, and after fault clearance conditions. But the fault does not much interpret the voltage of Voltage Source Converter. In this way, the Voltage Source Converter protects the DC microgrid from faults.

IV.1.1 Fault Condition (LLLG) of MMC

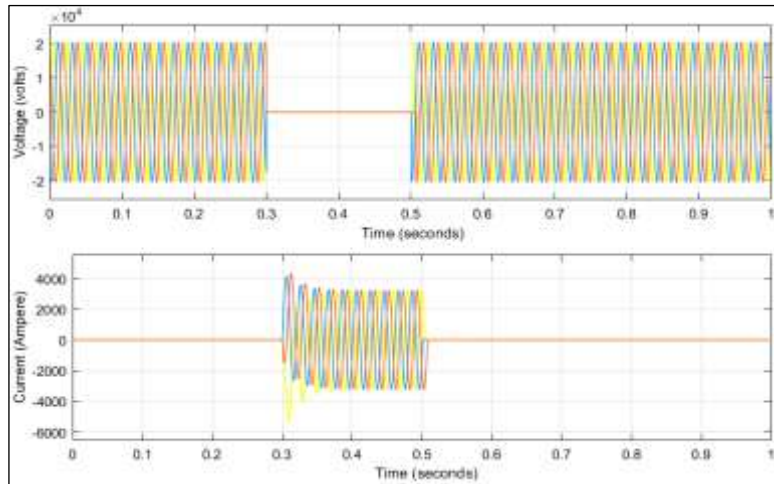

Figure 13: Voltage and current of AC Main Grid by using MMC.
Source: Authors, (2026).

The LLLG fault is applied between 0.3 and 0.5 seconds on the AC Main Grid. Variations of voltage and current in AC Main Grid are noted before, during, and after fault clearance conditions. But the fault does not much interpret the voltage of the modular multilevel converter.

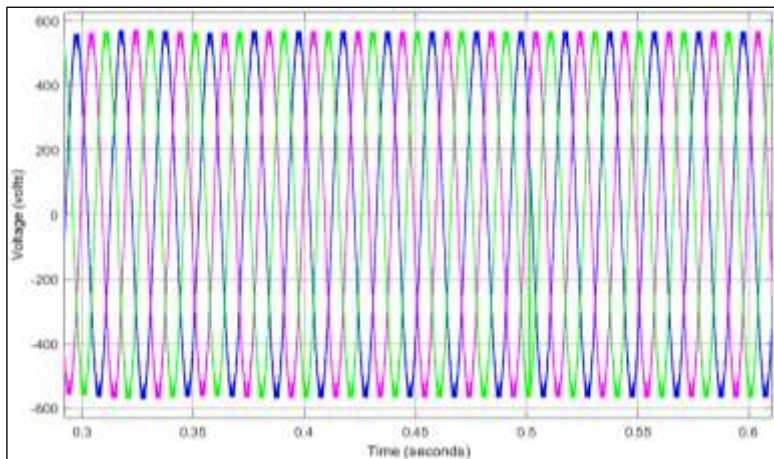

Figure 14: Voltage of MMC.
Source: Authors, (2026).

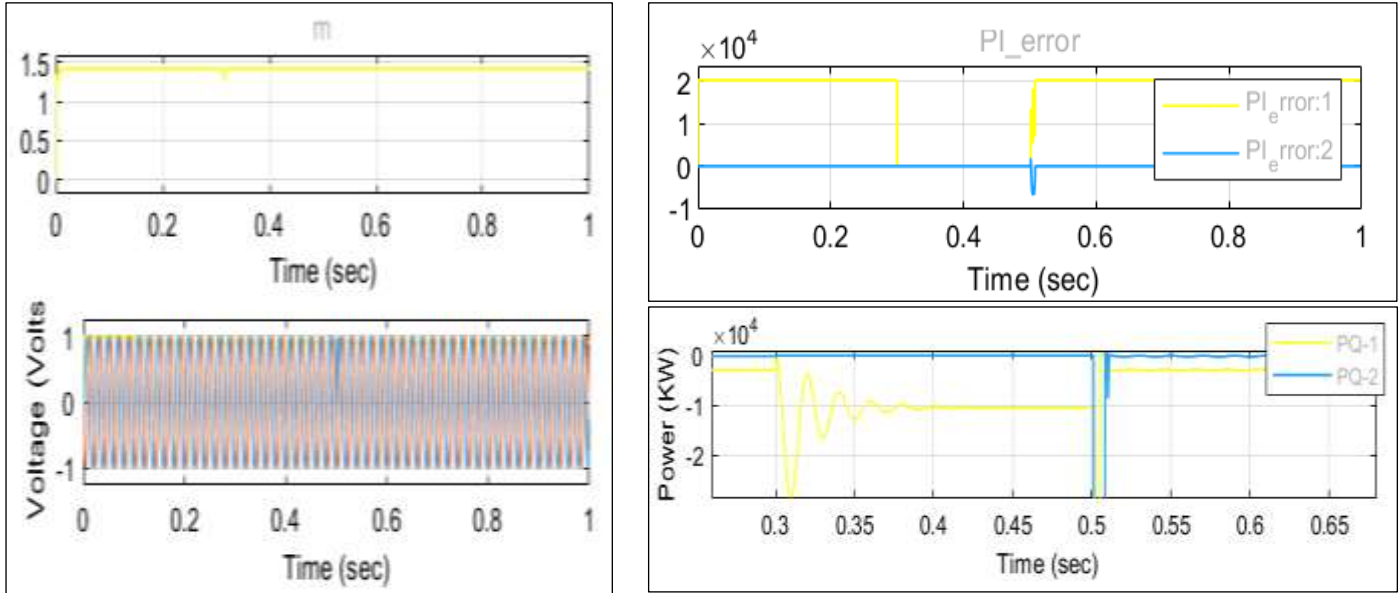

Figure 15: Waveforms of power and modulation index.
Source: Authors, (2026).

An inverter with six switches three for the positive arm and three for the negative arm is created using MMC circuit 32 IGBT. When the model is ready, it runs for one second, and on the AC Main Grid side, fault is imposed at time periods of 0.3 and 0.5 seconds. For voltage regulation, an MMC based on VSC is used. The triggering signal is produced by a triangle waveform generated by MMC with PWM [17], and the reference voltage is controlled by a circuit. The PWM input receives a reference voltage of 1pu that is generated in the controlling structure.

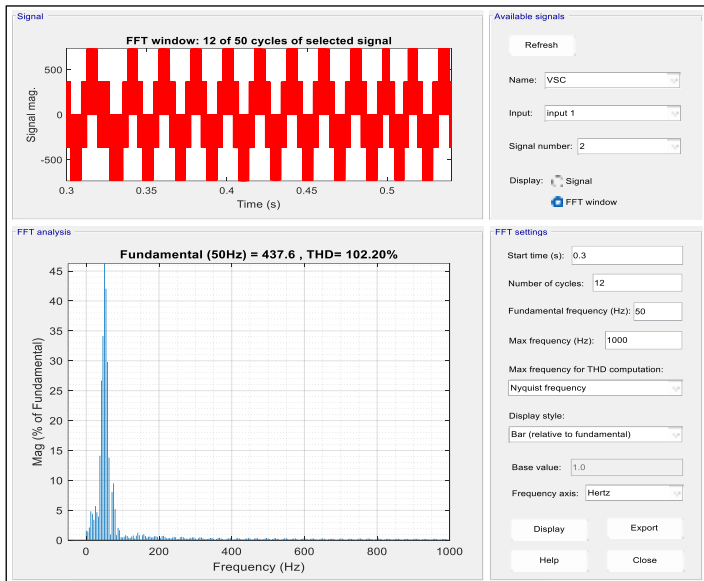

Figure 16: FFT Plot of VSC.
Source: Authors, (2026).

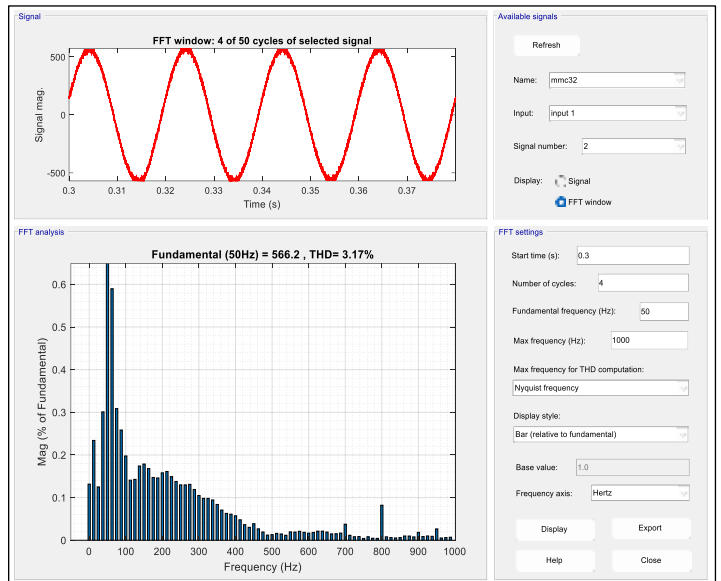

Figure 17: FFT Plot of MMC.
Source: Authors, (2026).

IV.1.2 Comparative Study

The Comparison of (THD)% of VSC and MMC is shown below.

Table 2: Comparison of (THD)% of VSC and MMC.

Parameters	VSC	MMC
Total Harmonic Distortion (THD)%	102.02	3.17
Fundamental Frequency (50Hz)	437.6	566.2

Source: Authors, (2026).

From the comparative study, the total harmonic distortion (THD) percentage of the voltage source converter (VSC) is 102.02%, whereas that of the modular multilevel converter (MMC) is 3.17%. The Modular Multilevel Converter (MMC) lowers harmonic frequencies. In terms of DC Microgrid protection, this indicates that the modular multilevel converter performs better than the voltage source converter.

V. CONCLUSIONS

MATLAB Simulink is used to analyze the DC microgrid's fault protection analysis using a VSC and a MMC. When compared to a voltage source converter, the THD analysis of a 32-level IGBT modular multilevel converter based on VSC exhibits good results. When the AC main grid has a fault, the 32-level IGBT modular multilevel converter based on VSC operates better at protecting the DC microgrid. The Power Electronics Building Block model is used due of the system's highly modular design and execution. Only a differential relay is used for fault protection and a PI controller is used. Neural network ANFIS converters, various relays and filters can be used further.

VI. AUTHOR'S CONTRIBUTION

Conceptualization: Kanna Sravanthi and Ayya Chaithanya.

Methodology: Kanna Sravanthi and Ayya Chaithanya.

Investigation: Kanna Sravanthi and Ayya Chaithanya.

Discussion of results: Kanna Sravanthi and Ayya Chaithanya.

Writing – Original Draft: Kanna Sravanthi.

Writing – Review and Editing: Kanna Sravanthi and Ayya Chaithanya.

Resources: Kanna Sravanthi.

Supervision: Ayya Chaithanya.

Approval of the final text: Kanna Sravanthi and Ayya Chaithanya.

VII. ACKNOWLEDGMENTS

The author is grateful to A. Chaithanya of SV University's Electrical & Electronics Engineering Department for her guidance in bringing this paper to completion. Also, the author likes to show thankfulness to all of the educational professionals in the electrical and electronics engineering Department in SV University who gave either direct or indirect support in completing this paper

VIII. REFERENCES

- [1] L. Zhang, N. Tai, W. Huang, J. Liu and Y. Wang, "A review on the protection of DC microgrids," in *Journal of Modern Power Systems and Clean Energy*, vol. 6, no. 6, pp. 1113-1127, November 2018.
- [2] Priya Ranjan Satpathy., "Advanced protection technologies for microgrids: Evolution, challenges, and future trends," in *Energy Strategy Reviews* Volume 58, March 2025, 101670.
- [3] Akshaykumar N. Wankhade, Prof. Roshan R. Deotare, "Protection scheme for unipolar mmc-based multi-terminal HVDC grid," 2021 JETIR July 2021, Volume 8, Issue 7.
- [4] T.Strasser, F. Andr n, J. Kathan, C. Cecati, C. Buccella, P. Siano, P. Leit o, G. Zhabelova, V. Vyatkin, P. Vrba, and V. Marik, "A review of architectures and concepts for intelligence in future electric energy systems," *IEEE Trans. Ind. Electron.*, vol. 62, no. 4, pp. 2424–2438, Apr. 2015.
- [5] Mohammed Ahmed Yagoub., "Modelling and Fault Protection Analysis of a DC Microgrid using Voltage Source Converter (VSC)," in 2020 International Conference on Computer, Control, Electrical, and Electronics Engineering (ICCCEEE) | 978-1-7281-9111-9/20/\$31.00 ©2021 IEEE|.
- [6] J. Y. Kim et al., "Cooperative Control Strategy of Energy Storage System and Microsources for Stabilizing the Microgrid during Islanded Operation," in *IEEE Transactions on Power Electronics*, vol. 25, no. 12, pp. 3037-3048, Dec. 2010.
- [7] Immanuel N. Jiya, Ahmed Salem, "Integrated Multiport DC-DC and Multilevel Converters for Multiple Renewable Energy Source Integration," *IEEE Access*, Digital Object Identifier 10.1109/ACCESS.2023.3336567, volume 11, 2023.
- [8] Rainer Marquardt, "Modular Multilevel converters State of the art and future progress," *IEEE Power Electronics Magazine*, 2018.
- [9] Ming Yu, Yi Wang, Lirong Zhang, Ziguang Zhang. "DC short circuit fault analysis and protection of ring type DC microgrid", 2016 IEEE 8th International Power Electronics and Motion Control Conference (IPEMC-ECCE Asia), 2016.
- [10] C. A. Apostolopoulos and G. N. Korres, "A Novel Algorithm for Locating Faults on Transposed/Untransposed Transmission Lines Without Utilizing Line Parameters," in *IEEE Transactions on Power Delivery*, vol. 25, no. 4, pp. 2328-2338, Oct. 2010.
- [11] Sumanth, Akash Srivastava and Sangeeta Modi, "Fault Analysis and Protection of DC Microgrid," *International Journal of Engineering Research & Technology (IJERT)*, volume 11, pp. 122-126, IETE-2020.
- [12] EYAN, Abhisek UKIL, "Simulation and Analysis of Faults in High Voltage DC Power Transmission," Nanyang Technological University, Singapore, 2014.
- [13] K. Sreedhar Kumar, J N Chandra Sekhar, "Limitation of Fault Currents by Positionind of Superconducting Fault Current Limiter in AC and DC Microgrid" *IEEE Trans.Power Del.*,vol. 4, no. 2, February. 2015. Maanickam KARTHIK.
- [14] R. M. Cuzner and G. Venkataraman, "The Status of DC Micro-Grid Protection," 2008 IEEE Industry Applications Society Annual Meeting, Edmonton, AB, 2008, pp. 1-8.
- [15] Jassem Mohammed., "Performance Analysis of Overcurrent Protection Schemes In Power Systems," in 2024 Advances in Science and Engineering Technology International Conferences (ASET) | 979-8-3503-4413-4/24/\$31.00 ©2024 IEEE |.
- [16] N. Bayati, A. Hajizadeh and M. Soltani, "Protection in DC microgrids: a comparative review," in *IET Smart Grid*, vol. 1, no. 3, pp. 66-75, 10 2018.

[17] S. Bernet, T. Matsuo, and T. A. Lipo, "A matrix converter using reverse blocking NPT-IGBTs and optimized pulse patterns," in Proc. 27th Annu. IEEE Power Electronics Specialists Conf., 1996, pp. 107–113.