

## OPTIMIZATION OF EV CHARGING SYSTEMS USING HYBRID GWO-PSO MPPT FOR PV SOURCE

Venkatesh Reddy Birudala<sup>1</sup>

<sup>1</sup>Department of EEE, Sri Venkateswara College of Engineering, Tirupati

<sup>1</sup><https://orcid.org/0000-0002-6827-8522>

Email: [venkateshreddy.b@svce.edu.in](mailto:venkateshreddy.b@svce.edu.in)

### ARTICLE INFO

#### Article History

Received: January 24, 2026  
Reviewed: February 28, 2026  
Accepted: April 7, 2026  
Published: April 30, 2026

#### Keywords:

Maximum Power Transfer,  
Grey Wolf Optimization,  
Electric Vehicle Charging,  
GWO-PSO MPPT,  
P&O MPPT.

### ABSTRACT

Electricity is produced from variety of fossil and renewable sources and it is crucial that EVs have to be powered from renewables. With Electric Vehicle penetration, the combination of PV with EV drastically reduce our dependence on fossil fuel based electricity plants. The day to day power demand needed and anyone with a solar power system is likely to install a solar power charging station in their home in upcoming years. Solar power is variable as irradiance is changing during the day so to accommodate the changing irradiance MPPT algorithm has to switch or reach the maximum power point quickly. A GWO-PSO based MPPT is proposed in this paper and compared with P&O, PSO and GWO MPPTs and the hybrid GWO-PSO MPPT is used to charge the Electric Vehicle.



Copyright ©2026 by authors and Galileo Institute of Technology and Education of the Amazon (ITEGAM). This work is licensed under the Creative Commons Attribution International License (CC BY 4.0).

### I. INTRODUCTION

India receives high levels of solar irradiance throughout the year due to its geographic tropical location, making it one of the most promising regions for harnessing solar energy. Government of India is encouraging solar energy through National Solar Mission with target of 450 GW by 2030. Many MW solar parks and Roof top solar panels are being subsidised to increase solar power generation. Solar power is produced when sun light hits a solar cell, the energy from the photons of light knocks electrons loose from their atoms. This produces an electric field, causing electrons to move across the cell enabling each cell to produce a little quantity of DC power [1]. Based on the requirement these solar cells are arranged in series or parallel which forms a PV array.

The sunlight is not uniform throughout the day. So the power produced from the solar cells changes with varying nature of sunlight. Hence a converter is needed to regulate the solar power output for obtaining a smooth supply. This converter operation is such that it also optimizes the power produced from the PV array using an MPPT controller. The block diagram of PV based EV charging system proposed in this work is shown in figure 1. This links a PV array to SEPIC Converter, a controller for switching on and off the converter and the EV battery as load.

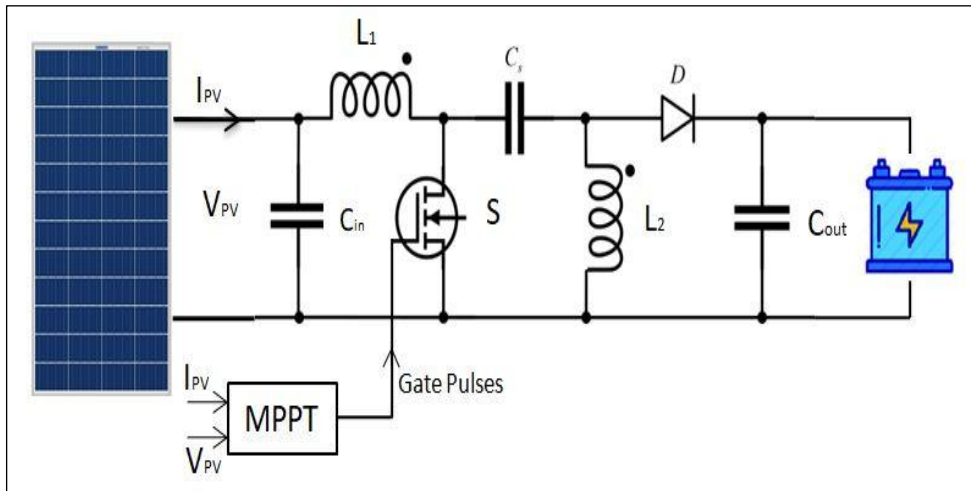

Figure 1: Block Diagram of PV based EV charging system.  
Source: Author, (2026).

## II. MPPT METHODS FOR PV SYSTEM

There are two main types of MPPT techniques (1) Indirect MPPT techniques and (2) Direct MPPT techniques

### II.1 INDIRECT MPPT TECHNIQUES

Indirect techniques are based on assumptions and periodic estimation of MPPT using simple measurements [2]. For instance, in the fixed voltage technique, the solar PV module is only adjusted according to the operating voltage at different times of the year [3] (i.e., winter, summer, etc.), with the assumption that the MPP voltages will be higher in the winter (cool period) and lower in the hot period i.e. summer when irradiation level is the same. This method is inaccurate because irradiation level and the temperature level changes in a season continuously. The next most commonly used indirect method is the Open Circuit Voltage (OCV) method. This can be obtained as

$$V_{MPP} = k V_{OC} \tag{1}$$

Where k is a constant often found to be between 0.7 and 0.8 for crystalline silicon.

This method is straightforward and easy to implement as compared to the other methods. The k constant is only an approximation, resulting in lower efficiency [4]. Every time when the illumination condition change, the system has to find a new open circuit voltages. To find this new open circuit operating voltage, the load on the PV module has to be disconnected, resulting in power loss. Compared to indirect methods, direct MPPT procedures are more exact and respond faster since they assess voltage, current, speed, or power. The block diagram for MPP Tracker as shown in the figure 2.

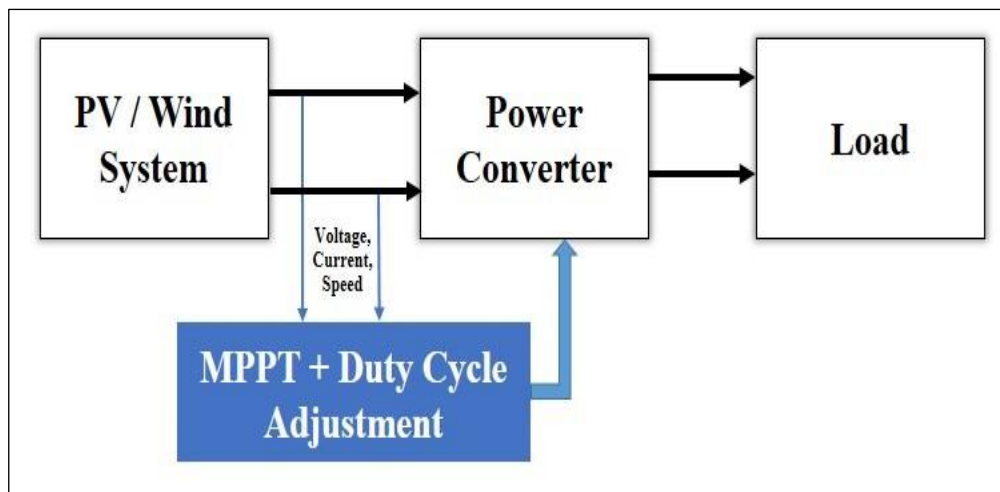

Figure 2: Block Diagram of MPP Tracker.  
Source: Author, (2026).

### II.2 DIRECT MPPT TECHNIQUES

Depending on the amount of sunlight, wind, and other factors, MPPT improves the efficiency of power extraction from renewable sources. By altering the load characteristics to run at maximum power, this maximizes system performance. In other words, it modifies the load characteristic according to the current circumstances [5]. To maximize the output, this method is connected to a converter. These are referred to as MPPT controllers or trackers.

An algorithm is used by an MPPT tracker to maximize the power produced. We use the Standard PV Test Conditions (STC) while testing renewable energy systems, however the system's operating conditions differ from the STC. Environmental variables including temperature, wind speed, and sunshine intensity affect how much power solar panels and wind turbines can produce. Maximum Power Point Tracking, or MPPT, is a crucial technology needed by solar and wind generating systems to maximize the power produced from sustainable energy sources. By using the maximum amount of power from the source, this technique ensures that the system operates as effectively as possible [6].

In MPP tracking the parameters like voltage, current, wind speeds are sensed from the renewable source and given to the MPP tracker. The tracker adjusts the load characteristic accordingly by using the duty-cycle of the power converter. This power converter then makes the system to operate at maximum value and feeds the load of the system. Perturb and Observe (P&O), Incremental conductance, PSO, GWO are the direct methods. In this work, P&O, PSO, GWO and GWO-PSO MPPT techniques are considered for PV based EV charging system for their simple operation and fast convergence.

### III. PERTURB AND OBSERVE MPPT FOR PV SYSTEM

The most frequent, widely used, and straightforward MPPT algorithm is perturb and observe approach. This algorithm's implementation is affordable, reliable, and efficient [7].

The P&O method periodically perturbs the array's terminal voltage, that is, increases or decreases, and compares the solar power generated with that of the preceding perturbation cycle. The P&O algorithm starts by slightly changing the operating point (voltage or current) by decreasing or increasing from the current value. After the perturbation, the algorithm observe the resulting change in power output. It enumerates the change in power ( $\Delta P$ ) by comparing the new power output with the previous one, The perturbation is considered to have shifted the PV array's operating point closer to the MPP if the array's operational voltage shifts in a specific direction and  $dP/dV > 0$ .

The P&O algorithm would then disrupt the PV array voltage in the same way. The PV array was then moved away from the MPP if  $dP/dV < 0$  because of the shift in operating point, and the P&O algorithm reverses the direction of the perturbation. The PV array operating point is shifted by the controller in a certain way if the operating voltage changes and the power increases, and in the opposite direction otherwise. The subsequent perturbation cycle follows the same procedure. P&O algorithm requires minimal computational resources but it may cause oscillations and drift when the irradiance and temperature changes quickly. To overcome this advanced algorithms is modified and implemented in this work. The duty cycle of the converter varies in the P&O approach by observing the voltage and power perturbation, i.e., either  $P \ \& \ v$  both are greater than zero or  $P < 0 \ \& \ V > 0$  [8].

### IV. PSO MPPT FOR PV SYSTEM

PSO involves a population-specific optimisation method modelled after fish or bird social structures. A population of possible solutions, or particles, traverses the search space in PSO. Based on its own experience as well as the experiences of its neighbours in the search space, each particle modifies its position [9]. In PV systems, PSO aims to maximise the operating parameters as voltage and current. Each particle represents a possible solution for the operating parameters. The particles are initialised with random duty cycles, for each particle fitness is checked for the PV power. Particle positions are updated by taking into account both their neighbours' and their own best-known positions. When all the particles are completed, the best particle's parameters are compared to maximum power [10].

Particle locations are updated repeatedly via multiple iterations until the converging requirement of maximum power is satisfied. If the maximum power point is reached, then the algorithm is said to be converged else it will change the phase of particles till the maximum power convergence is reached. The PSO algorithm continuously adjust the PV system's operating point, guaranteeing that it runs at its maximum power point in a variety of environmental circumstances. The efficiency and generation of energy produced by solar panels are increased due to this optimisation.

### V. GWO MPPT FOR PV SYSTEM

Grey Wolf Optimisation is a metaheuristic optimization method which belongs to the class of algorithms inspired by nature and designed to mimic the group behaviors of social organisms. It was motivated by the social interactions of grey wolves [11]. The algorithm is meant to resemble the natural hunting and leadership structure of grey wolves. GWO involves leader grey wolves which are crucial to the basic concept of GWO. The remaining wolves, or search agents, are regarded as fellow pack members. The method searches for the best answer to a given problem by iteratively updating the positions of these wolves [12]. The time to reach the maximum power point is quick in GWO compared to PSO [13].

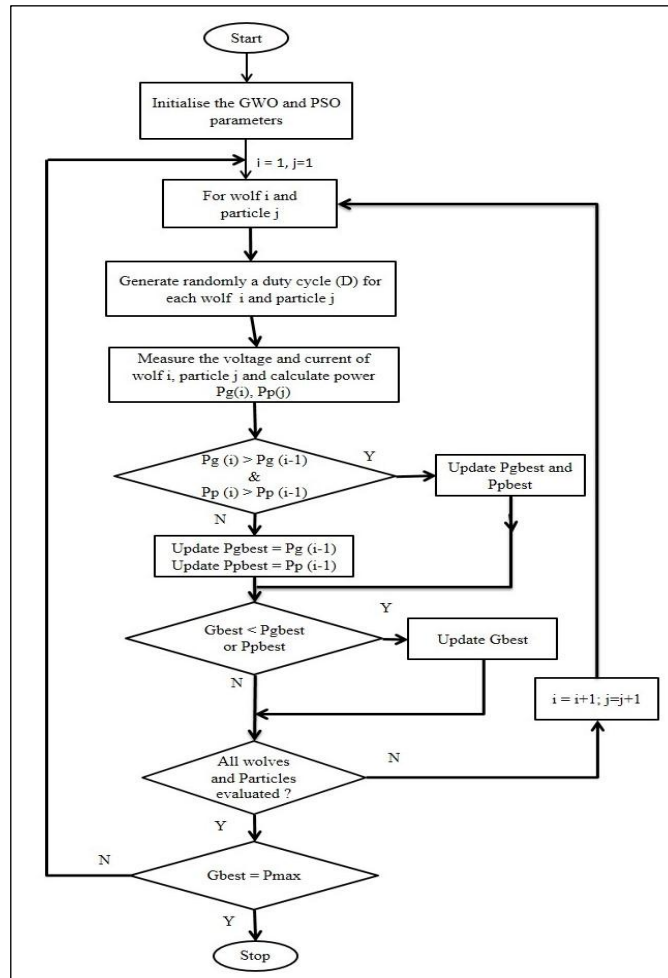

Figure 3: Flowchart of GWO-PSO MPPT. Source: Author, (2026).

### VI. GWO-PSO MPPT FOR PV SYSTEM

PSO MPPT has limitations such as Convergence during dynamic conditions and sensitive to parameters like inertia weight and social coefficient. GWO has limitations like balancing exploration during dynamic conditions, these limitations can be mitigated by using hybrid GWO-PSO MPPT. The flowchart of hybrid MPPT is shown in figure 3. The parameters of GWO, PSO with PV panel's maximum values is initialized and the hierarchy of wolves are generated according to the readings from the panel. Similarly PSO particles are initialized and Pbest is found. For each wolf the power is assessed and it is compared with the pack best solution.

Now the positions of Particles and wolves are combined and new power is reached. If this new power is equal to maximum power the algorithm stops else the wolves are iterated again with updated position till the convergence of maximum power occurs. When the wolves locate the MPP, the associated coefficient vectors are almost equal to zero. The algorithm placed in a Simulink block for testing the PV system with GWO MPPT technique. The above MPPT techniques are tested with Matlab/Simulink code for PV based EV charging system which is discussed in the next section.

### VII. TESTING OF PV BASED EV CHARGING SYSTEM WITH MATLAB/SIMULINK

All the proposed MPPT techniques with PV based EV charging system is tested with MATLAB/Simulink Environment and the simulation model is shown in figure 4 and the parameters used in simulation are given in Table 1.

Table 1: Parameters of PV based EV charging system.

PV ARRAY		Battery	
Parameter	Value	Parameter	Value
Open Circuit Voltage ( $V_{oc}$ )	36.6V	Nominal Battery Voltage	24 V
Short Circuit Current ( $I_{sc}$ )	8.75A		
Voltage at MPP ( $V_{mp}$ )	30.86V	Rated Ah Capacity	50 Ah
Current at MPP ( $I_{mp}$ )	8.1A		
Maximum Peak Power of PV Array	2000 W	Initial SoC	50 %
Temperature	250 C		

Source: Author, (2026).

In the simulation model, the inputs to PV array block is irradiance and temperature. The irradiance input is provided using constant block for fixed input and using a staircase generator for variable input. The parameters of PV array is initialised to MPPT block. The MPPT algorithm is coded in this block and it provides gate signals to the switch of DC-DC converter. The power from PV is given to EV load through SEPIC converter and the charging parameters are observed. Simulink model of PV based EV charging system is tested at standard test conditions of 1000 w/m<sup>2</sup> irradiance and 250 C with P&O, PSO, GWO and GWO-PSO MPPT techniques, the corresponding PV power output waveforms are shown in figure.

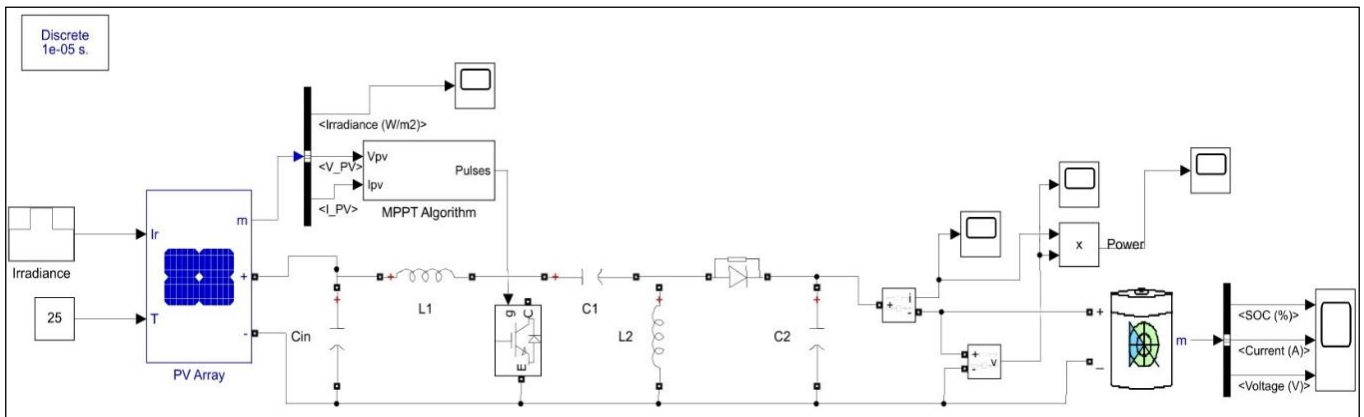

Figure 4: Simulink Model of PV based EV charging System.  
Source: Author, (2026).

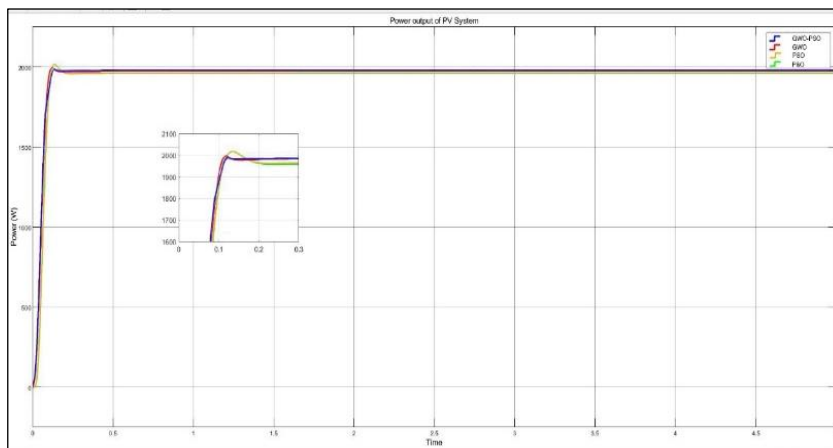

Figure 5: PV Power output under standard test condition.  
Source: Author, (2026).

From the figure, it is observed that the power output with different MPPT techniques. Blue represents power with GWO-PSO, red represents power with GWO, gold represents power with PSO and green represents power with P&O and the corresponding numerical values are shown in the table 2. At standard test conditions all the MPPT techniques are having similar output. So the system is tested for variable irradiance conditions. As the irradiance increases from morning to noon and decreased from noon to evening. This variable irradiance is given by using a staircase generator changing from 500 W/m<sup>2</sup> to 800 W/m<sup>2</sup>, 800 W/m<sup>2</sup> to 1000 W/m<sup>2</sup>, 1000 W/m<sup>2</sup> to 800 W/m<sup>2</sup>, 800 W/m<sup>2</sup> to 500 W/m<sup>2</sup> at the instants 1, 2, 3 and 4 respectively which is shown in the figure 6 with the temperature of 25<sup>0</sup> C and the corresponding power output is shown in figure 7.

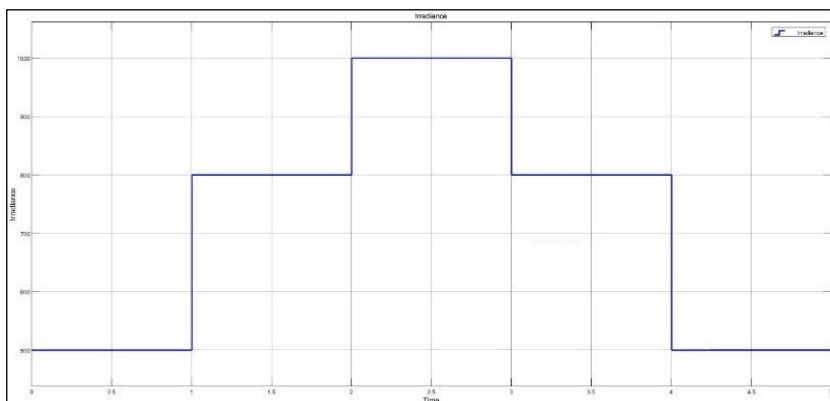

Figure 6: Variable Irradiance input.  
Source: Author, (2026).

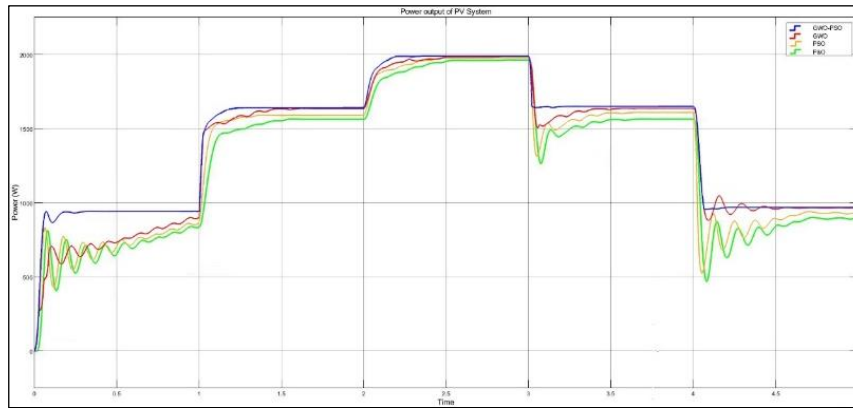

Figure 7: PV Power output under variable irradiance.  
Source: Author, (2026).

From the figure 7, the power output of the PV System and time of reaching maximum power point with P&O, PSO, GWO and GWO-PSO at variable irradiance and the corresponding test results are tabulated in Table 2.

Table 2: Comparison of Power output of PV based EV charging system.

Irradiance (W/m <sup>2</sup> )	Power Output (W)				Time taken to reach MPP (sec)			
	P&O	PSO	GWO	GWO-PSO	P&O	PSO	GWO	GWO-PSO
500	872	880	894	908	0.94	0.94	0.94	0.3
800	1628	1642	1664	1672	0.59	0.38	0.61	0.22
1000	1972	1984	1988	1990	0.51	0.46	0.45	0.22

Source: Author, (2026).

From the table 2, it is observed that GWO-PSO MPPT method is reaching maximum power point faster when the irradiance is changing as compared to other MPPT Techniques. Therefore, GWO-PSO MPPT is applied to PV system and tested under variable irradiance condition for analysing the SOC of EV battery. Further, GWO-PSO MPPT is applied to PV system and EV Battery and tested under variable irradiance condition. SOC represents the percentage of rated capacity left in the battery. While charging SOC of battery increases and it gets decreased during discharging. From the above analysis, the SOC, Voltage and Current of EV battery is shown in figure 8.

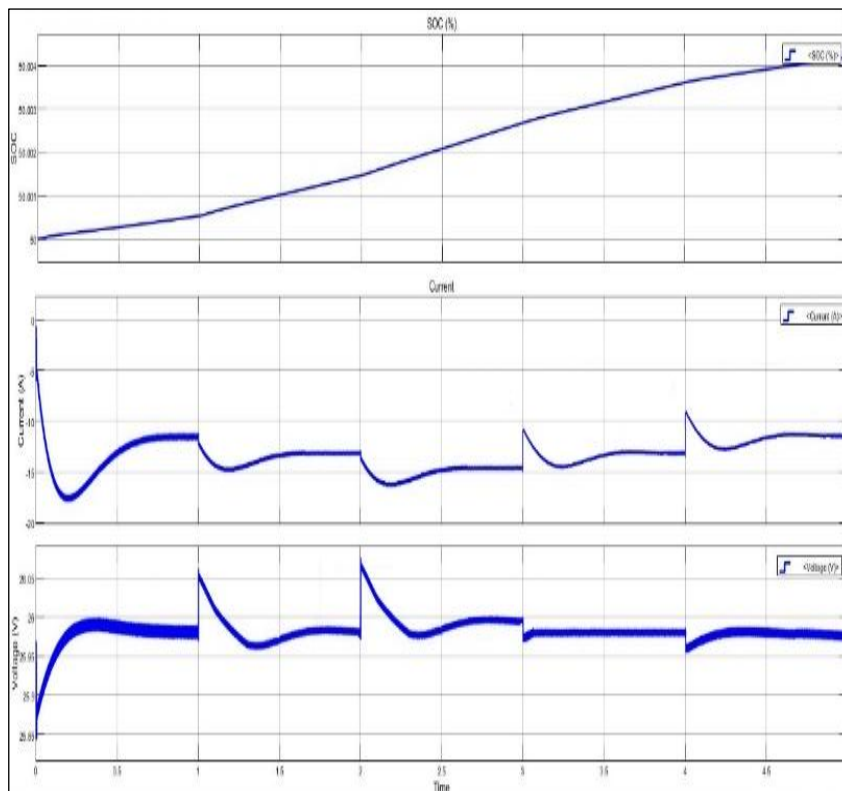

Figure 8: SOC, Current and Voltage of EV Battery.  
Source: Author, (2026).

From the figure, it is observed that the SOC is increasing and the current is in negative magnitude, so the system is in charging state. The charging current and SOC slope got changed with changing irradiance.

## VIII. CONCLUSIONS

In this paper, a charging system for Electric Vehicles based on PV power with SEPIC converter is discussed and tested in MALAB/Simulink environment with P&O, PSO, GWO and GWO-PSO MPPT Techniques under STC and variable irradiance. It is observed that of all the four techniques the GWO-PSO MPPT technique is reaching the MPP faster with better output magnitude.

## IX. AUTHOR'S CONTRIBUTION

**Conceptualization:** Venkatesh Reddy Birudala.  
**Methodology:** Venkatesh Reddy Birudala..  
**Investigation:** Venkatesh Reddy Birudala..  
**Discussion of results:** Venkatesh Reddy Birudala..  
**Writing – Original Draft:** Venkatesh Reddy Birudala..  
**riting – Review and Editing:** Venkatesh Reddy Birudala..  
**Resources:** Venkatesh Reddy Birudala.  
**Supervision:** Venkatesh Reddy Birudala..  
**Approval of the final text:** Venkatesh Reddy Birudala..

## X. ACKNOWLEDGMENTS

I thank Prof. Ch. Chengaiah, Department of EEE, SVU College of Engineering for his continuous encouragement in doing my research work and writing this paper.

## XI. REFERENCES

- [1] N. Kaushika, A. Mishra, and A. K. Rai, "Solar Photovoltaic System Design," *Solar Photovoltaics*, vol. 58, pp. 115-126, 2018.
- [2] P. Gonçalves, V. Sampaio, M. Orestes and A. González, "Photovoltaic solar energy: Conceptual framework", *Renewable and Sustainable Energy Reviews*, Volume 74, 2017, Pages 590-601, ISSN 1364-0321, <https://doi.org/10.1016/j.rser.2017.02.08>.
- [3] B. Boualem & B. Hocine and K. Fateh, 2015. "A survey of the most used MPPT methods: Conventional and advanced algorithms applied for photovoltaic systems," *Renewable and Sustainable Energy Reviews*, Elsevier, vol. 45(C), pages 637-648.
- [4] B. V. Reddy and C. Chengaiah, "A Modified P&O Technique for Solar based EV Charging with SEPIC," 2023 Fifth International Conference on Electrical, Computer and Communication Technologies (ICECCT), Erode, India, 2023, pp. 1-4, doi: 10.1109/ICECCT56650.2023.10179607.
- [5] R. Bollipo, S. Mikkili, & P. Bonthagorla, "Critical review on PV MPPT techniques: classical, intelligent and optimisation", *IET Renewable Power Generation*, vol. 14, no. 9, p. 1433-1452, 2020. <https://doi.org/10.1049/iet-rpg.2019.1163>
- [6] Sevty Satria Bhatara, Reza Fauzi Iskandar, M. Ramdhan Kirom; Design and simulation of maximum power point tracking (MPPT) system on solar module system using constant voltage (CV) method. *AIP Conf. Proc.* 24 February 2016; 1712 (1): 030012. <https://doi.org/10.1063/1.4941877>.
- [7] Baimel, D.; Tapuchi, S.; Levron, Y.; Belikov, J. Improved Fractional Open Circuit Voltage MPPT Methods for PV Systems. *Electronics* 2019, 8, 321. <https://doi.org/10.3390/electronics8030321>.
- [8] A. Nigam, A. K. Gupta and S. Sharma, "Simulation of Modified P&O MPPT Technique for Solar PV Cell using MATLAB/SIMULINK", *International J. Engineering and Technology*, vol. 3, no.4, pp. 264-267, Apr. 2016.
- [9] Hossain, M. J., & Ali, M. H. (2017). A comprehensive review of optimization techniques in solar photovoltaic applications. *Renewable and Sustainable Energy Reviews*, 71, 605-617.
- [10] Vodapally, S.N.; Ali, M.H. A Comprehensive Review of Solar Photovoltaic (PV) Technologies, Architecture, and Its Applications to Improved Efficiency. *Energies* 2023, 16, 319. <https://doi.org/10.3390/en16010319>.
- [11] Mirjalili, S., Mirjalili, S. M., & Lewis, A. (2014). Grey Wolf Optimizer. *Advances in Engineering Software*, 69, 46-61. DOI: 10.1016/j.advengsoft.2013.12.007.
- [12] M.H.Hassan, A. Jamali et.al, (2022). Grey Wolf Optimization For Intelligent Parametric Modeling Of Gradient Flexible Plate Structure, *Journal of Applied Science and Engineering*, Vol. 26, Issue 9, November 2022, pp.1205-1212.
- [13] Kraiem, H.; Aymen, F.; Yahya, L.; Triviño, A.; Alharthi, M.; Ghoneim, S.S.M. A Comparison between Particle Swarm and Grey Wolf Optimization Algorithms for Improving the Battery Autonomy in a Photovoltaic System. *Appl. Sci.* 2021, 11, 7732. <https://doi.org/10.3390/app11167732>