

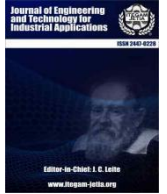

ISSN ONLINE: 2447-0228







RESEARCH ARTICLE
OPEN ACCESS

DESIGN AND DEVELOPMENT OF IOT BASED AUTOMATED ATTENDANCE SYSTEM USING FACIAL RECOGNITION

George Michael G. Makigod¹, Janwel Josh B. Sebastian², Edwin R. Arboleda³, and Luisa Ann T. Ongquit*⁴

^{1, 2, 3, 4}Cavite State University – Main Campus – Cavite, Philippines.

¹<http://orcid.org/0009-0001-9068-0155>  ²<http://orcid.org/0009-0005-2377-9154> , ³<http://orcid.org/0000-0001-9371-8896> ,
⁴<http://orcid.org/0009-0009-2534-5252> 

Email: georgemichael.makigod@cvsu.edu.ph, janweljosh.sebastian@cvsu.edu.ph, edwin.r.arboleda@cvsu.edu.ph, *mrs14.la.ongquit@gmail.com

ARTICLE INFO

Article History

Received: November 26th, 2023

Revised: July 08th, 2024

Accepted: July 19th, 2024

Published: August 30th, 2024

Keywords:

IoT Based Automated Attendance System, Facial Recognition Attendance System, Fingerprint Attendance System, Radio Frequency Identification (RFID) Attendance System.

ABSTRACT

The IoT Based Automated Attendance System was designed and developed to make an efficient contactless attendance marking system with a mobile application feature. This study aimed to improve the traditional attendance log system and contact fingerprint attendance within an institution through the use of facial recognition. The study used the OpenCV and Python Programming in order to create the facial recognition program, while the mobile application was developed through the use of Visual Studio Code and Android Studio. The prototype was composed of mini pc which handled all the processes the device had to execute. The computer was used to interface other components of the device such as webcam, monitor, keyboard, and mouse. Since this is an automated attendance system, portability and efficiency were given importance. The prototype's performance was tested and monitored through the use of 100 participants including the researchers themselves. The project was tested by the Department of Computer, Electronics, and Electrical Engineering (DCEE) at the Engineering Science Building, Cavite State University, Indang, Cavite with the Electronics Engineer Professors. Based on the results of the evaluation, the design project succeeded in achieving its objectives. The overall performance was considered satisfactory. The cost computation of the system amounted to PHP 14,150.00.



Copyright ©2024 by authors and Galileo Institute of Technology and Education of the Amazon (ITEGAM). This work is licensed under the Creative Commons Attribution International License (CC BY 4.0).

I. INTRODUCTION

Attending marking procedures was probably the most challenging responsibility in any organization [1]. Since before, recording of attendance are always done manually. Even though this helped develop a student-teacher bond, it is prone to human errors and consumed more time [2]. Attendance tracking systems hold significant importance for all organizations, despite their complexity and the time required to manage routine attendance records [3]. Managing attendance manually within educational institutions was consistently challenging. This type of task demands a substantial amount of physical effort. Furthermore, it places additional load on teachers and academic administrators [4], to eliminate minimize time wastage, the implementation if an

Automatic Attendance Management System becomes essential. This step not only enhances efficiency but also boosts effectiveness. The existing system is fraught with a considerable amount of uncertainty, leading to inaccuracies and inefficiencies in attendance tracking and record maintenance. Numerous challenges emerge when the institution is unable to enforce the regulations within the current system. Therefore, through technological means, the project aimed to address the shortcomings present in the current system. By automating most tasks, it seeks to elevate attendance tracking to a significantly improved level [1],[2].

Numerous automated techniques exist for human identification, including biometrics, Radio Frequency Identification (RFID), eye tracking, and voice recognition. Among

these, facial recognition stands out as one of the most extensively employed biometric methods for authenticating human identity [3].

Over the past two decades, the field of facial recognition has emerged as a significant and captivating area of research. A facial recognition system is a software application designed to authenticate and identify individuals using images or videos from a given source [5].

In this paper, the researchers made use of the digital age. By utilizing modern technology in order to accelerate this means and provide time efficiency. The main purpose of this project was to create an automated attendance marking system in means of upgrading current attendance system economical and more efficient. The researchers decided to design and develop an IoT based automated attendance system using facial recognition with the use of a mini computer, webcam/camera, and a mobile application.

By utilizing the Python programming language, the development of a facial recognition program and an automated attendance system became achievable. The system facilitates the automatic organization of attendance records into an Excel spreadsheet, delivering neatly arranged and structured information for easy viewing and management.

The development of this system would help faculty workers in organizing the attendance log more efficiently. The mobile application provided will also help both students and instructors who needs information whether someone specific is currently present or absent for the day.

II. THEORETICAL REFERENCE

II.1 RADIO FREQUENCY IDENTIFICATION ATTENDANCE SYSTEM

For [2] discussed a smart attendance system of students in an educational institution. Furthermore, this system makes automated analysis and prepares a detailed report weekly, monthly and annually. The whole system was developed with an Arduino microcontroller and RFID readers. Also, GSM and WiFi communication modules are used to make convenient communication depend on the availability of the network. A microchip (microSD) is placed to store data in case of communication failure and those stored data will be uploaded bulk when the communication channel was restored. This system will reduce a lot of manual work of educators and education administrators of an education institution.

According to [6] implemented an RFID Based Automatic Attendance system, where the attendance tracking was automated using RFID technology. The attendance software was developed using VB.net, and a Microsoft Access database was employed. Each student was assigned an RFID tag attached to their Student ID card. A serial connection facilitates communication between the computer and the RFID reader. The RFID reader was positioned at the entrance of the lecture hall. When students entered the lecture hall, the RFID reader read the RFID tag, captures information such as entry time and name, and stores this data in the database via the serial connection. The system was managed through this approach. The system allows the

administrator to conveniently access all attendance records through the software interface. By retrieving information directly from the database, the software interface simplifies the process compared to traditional methods. Staff employees record attendance for both in-class and absentee students using the traditional method.

According to [7] developed an attendance system that merges RFID technology with a web-based approach. This system involves the use of RFID tags and readers to record students' attendance and identify specific students. The RFID reader communicates with an Arduino microcontroller, which then transfers the RFID reader's data to a web server through an Arduino shield. This data was subsequently stored in a web server using PHP and MySQL. Through a dedicated webbased application, the system's administrator can access and review all students' attendance records. Additionally, the administrator can view individual student details using LCD displays. This combination of RFID and web-based technologies enhances the efficiency of attendance management and provides a user-friendly interface for administrators to monitor and manage attendance data.

For [8] introduced a system that integrates RFID and GSM technologies. In this system, a microcontroller (LPC) acts as an intermediary between the GSM module and the RFID components. When students enter the classroom, they are required to use their RFID tag, which is then read by the RFID reader. This information is transmitted to the GSM module to signal their presence. If the tag's ID does not match any entry in the database, it is regarded as unauthorized access. Conversely, if the ID was valid, the GSM module sends notifications to both the administration and parents, confirming the student's attendance.

For [9] designed a prototype for an attendance management system, incorporating a higher quantity of RFID readers strategically positioned within a room. This setup is supported by a server application that is managed through a laptop. The connection between the RFID readers and the laptop or PC is established using either a wireless router or a LAN connection. Upon entering the room, individuals are required to utilize their RFID tag, which is then scanned by the RFID reader. Subsequently, the attendance information is transmitted to the server either via wireless communication or a LAN connection. The utilization of multiple RFID readers allows for simultaneous attendance recording for multiple individuals, leading to greater efficiency in comparison to traditional methods.

II.2 FINGERPRINT ATTENDANCE SYSTEM

Automated fingerprint identification involved the automated comparison of one or multiple unknown fingerprints against a database containing known and unknown prints. This process was used to identify matches and potential matches. Automated fingerprint verification is a closely aligned technique used in various applications like attendance and access control systems. At a technical level, verification systems confirm a claimed identity (for instance, a user claiming to be John using a PIN or ID card, verifying their identity through fingerprint

verification). In contrast, fingerprints, without the need for additional claims or information [10].

According to [11] addresses the prevalent issue of high levels of impersonation occurring regularly in both private and public sectors. The "ghost worker syndrome," which has become a widespread problem across various government tiers, as well as employers' concerns about workforce absenteeism, and challenges in managing student attendance during lectures are discussed. As a response to these challenges, the paper presents the development of a fingerprint-based Attendance Management System. This system aims to offer a quicker, more secure, and more convenient means of user verification compared to traditional methods such as passwords and tokens. This innovative approach provides a reliable method for personal identification, addressing the identified issues related to attendance and identification in various sectors.

According to [12] developed an attendance management system using biometrics to address the challenge of managing student attendance during lecture periods. Manual computation of attendance often leads to errors and consumes significant time. To tackle this issue, they designed an efficient system that electronically records attendance using a fingerprint device and stores the data in a database. Student identification is achieved through a biometric (fingerprint) system, eliminating the need for traditional record-keeping materials and personnel. In testing the system with eighty candidates, it achieved a success rate of 94 percent. Comparing execution times, the manual attendance system took an average of 17.83 seconds for eighty students, while the automatic attendance management system using biometrics reduced the time to 3.79 seconds. These results demonstrate a substantial improvement in performance over the manual attendance management system, with attendance being marked after student identification.

II.3 FACIAL RECOGNITION ATTENDANCE SYSTEM

There are many biometric systems that use features such as face, iris, fingerprint, palm print. Among these, facial recognition is an important contribution to technology. Facial recognition is used not only in the office environment and at immigration control at the airport, but also in the use of robots, cameras, digital photos and popular websites such as Facebook. It is a versatile solution with wide application and innovation in many areas [13].

In [14] the past suggested facial recognition as an attendance tracking system for schools to make the current attendance system more efficient and effective. There is a lot of confusion in the current legacy system, resulting in inaccurate onboarding and poor performance. Many problems arise when authorities cannot enforce the rules contained in the old system. The technology behind it will be the facial recognition system. The human face is one of the natural features that can identify a human being. It is therefore used to keep track of characters due to the deviation, or rather less, of the time of the face. In this project, a face database will be created to feed the data into the recognition algorithm. The face is then compared to the data to find the identity upon joining. Once a person is identified, their participation will be recorded and the necessary information will

[3] proposed deep learning-based facial recognition. They used three pre-trained convolutional neural networks for transfer learning and trained them with their own data. Our networks, GoogleNet, SqueezeNet, and AlexNet, perform very well in terms of prediction accuracy and reasonable training time.

For [15] Proposed the idea of using "automatic enrollment based on facial recognition." The app includes time-saving facial recognition and is software-only and can be saved as user-friendly as it reduces the amount of paper used. The system also eliminates the possibility of fraudulent participation because the face is used as a biometric for authentication. Therefore, this system can be used in areas where participation is important.

II.4 FACIAL RECOGNITION USING OPENCV

According to [16] has put forward a proposal to develop an application that enables user access to a specific machine by conducting a thorough analysis of an individual's facial features. This application's development relied on the utilization of Intel's open-source computer vision project, OpenCV, in combination with Microsoft's .NET framework.

According to [17] introduced an effective approach to detecting and recognizing human faces utilizing OpenCV and Python as part of deep learning. They detailed the utilization of deep learning, a vital aspect of the computer science field, for facial detection by employing various OpenCV libraries in conjunction with Python. Additionally, they outlined a proposed system for realtime human face detection. This implementation has versatile applications across platforms, including machines, smartphones, and various software applications.

For [18] paper provides comprehensive instructions on various image processing tasks. These include reading and writing images, displaying images, resizing them, and crucially, detecting and recognizing individuals' faces. The paper delved into methods for accurately identifying and associating the detected faces with their corresponding individuals.

For [19] conducted a presentation that involved the evaluation and comparison of various face detection and recognition algorithms utilized within the system. The system's workflow started with a training image of a person, followed by processing a test image. It identifies the face, compares it to the trained image, and ultimately classifies it through the utilization of OpenCV classifiers. The research explored the most efficacious techniques employed in this system, implemented through Python, OpenCV, and Matplotlib. Additionally, the application of this system in areas equipped with CCTV, such as public spaces, shopping malls, and ATM booths, is considered.

OpenCV classifiers. The research explored the most efficacious techniques employed in this system, implemented through Python, OpenCV, and Matplotlib. Additionally, the application of this system in areas equipped with CCTV, such as public spaces, shopping malls, and ATM considered.

According to [5] provided an extensive explanation of the complete process involved in creating a facial recognition system using the OpenCV library. The researcher employed the Haar cascading algorithm from the OpenCV library for face detection.

This algorithm utilized specific facial features for identification purposes. Numerous individuals' facial features were stored and indexed, enabling identification based on these distinctive features. The field of facial testimony and recognition presents significant challenges and complexities. The credibility of facial recognition systems relies on their accuracy and precision. The facial recognition technique involves capturing an image through a camera and then comparing it to the images stored in a database. If the captured image matches any of the stored images, it signifies a successful face match; otherwise, it indicates that the faces do not match.

III. MATERIALS AND METHODS

The project uses a Dell OptiPlex 3020 Micro Desktop i3-4160T, Samsung B2030 Monitor, Limeide T13 Keyboard and Mouse, and Oshare WB-01 Webcam. The chassis is made from marine plywood, wood, and rubber caster wheels. Locks are provided for security. The prototype aims for portability, availability, and usefulness.

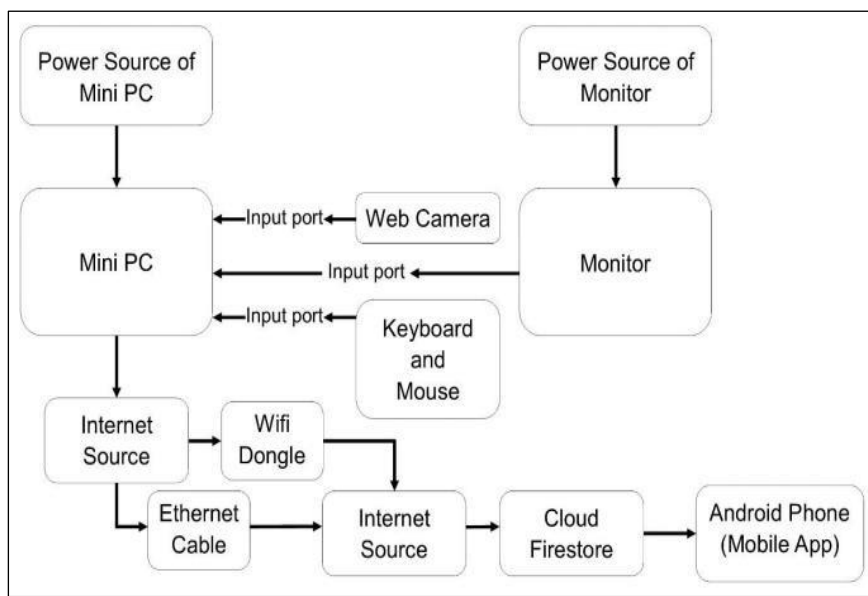

Figure 1: Block diagram of the system.
Source: Authors, (2024).

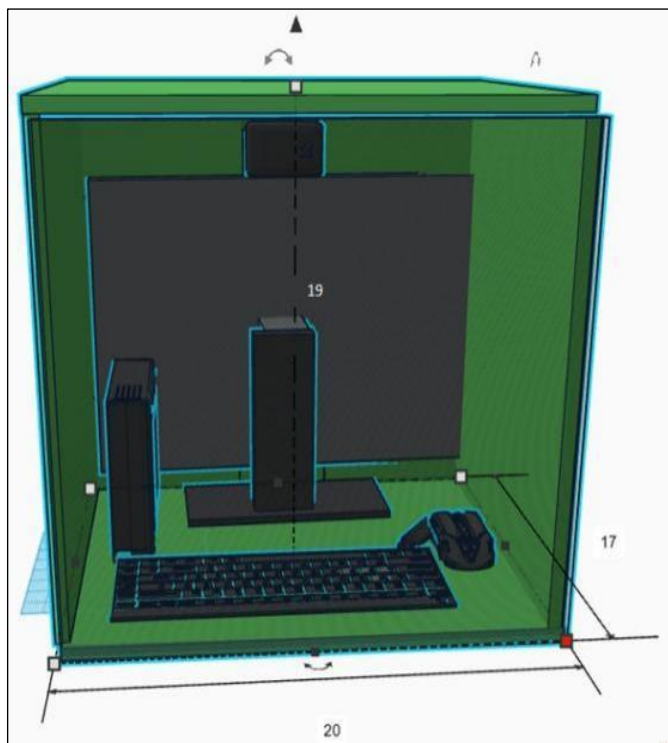

Figure 2: Internal view of the chassis.
Source: Authors, (2024).

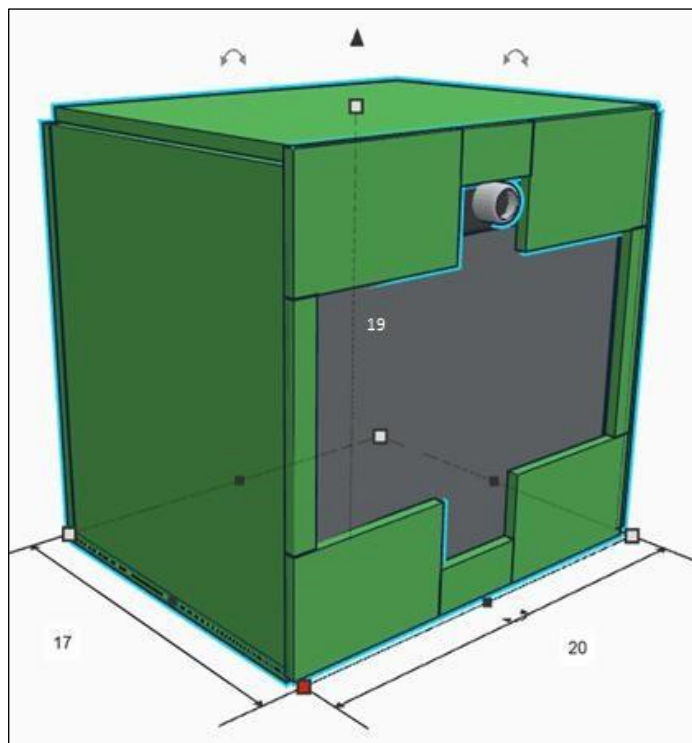

Figure 3: External view of the chassis.
Source: Authors, (2024).

The device's chassis is made of marine plyboard, a sturdy, affordable wood used for house constructions. It features removable top and back panels for easy wire management and cleaning, and measures 19 inches in height, 20 inches in length, and 17 inches in width.

III.1 DEVELOPMENT OF THE SYSTEM SOFTWARE AND GRAPHICAL USER INTERFACE

Python is a widely-used, easy-to-learn, and flexible programming language that supports object-oriented programming and built-in data structures. The system software was developed on a Mini PC, integrated with a Samsung B2030 Monitor for a graphical user interface. The project's front-end system displayed device readings and camera previews. Variables were initialized, and a flowchart was used to create the source code for the program's operation.

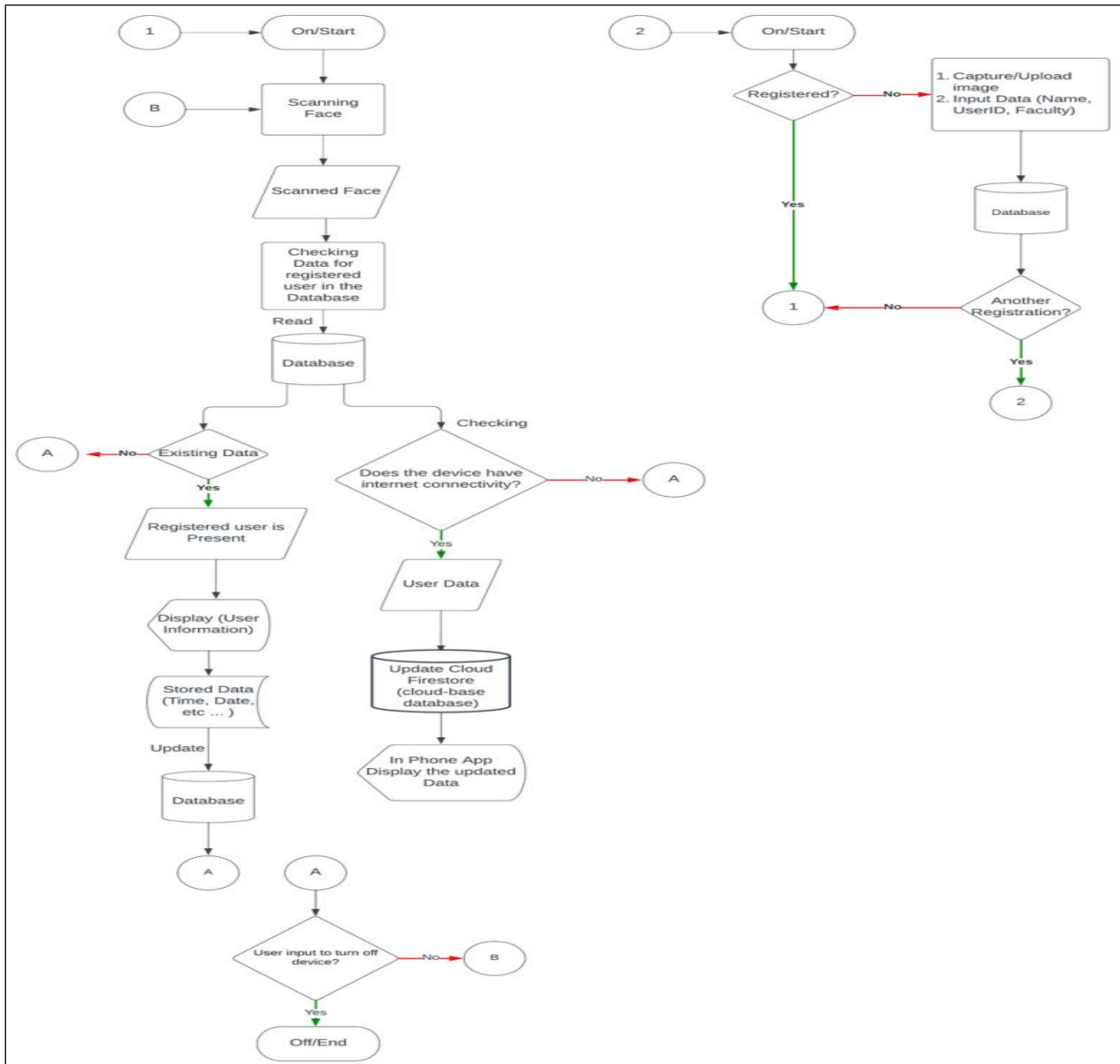

Figure 4: The flowchart of the IoT based automated attendance system.

Source: Authors, (2024).

Figure 4 shows the flowchart of the system. The program registers a user in the system, trains their reference image, and captures their face using a web camera. The program encodes the face in a database to determine if the user is in the system. If the user is, a "Success!" prompt appears, along with the scanned user's information. The user's time and date are automatically logged in an excel sheet, and the information is uploaded to the cloud. The process repeats for each user until the device is turned off.

The mobile application for an IoT-based automated attendance system was developed using PyCharm, Python's official IDE. It provides real-time information about registered users, uploading their data to Firestore Cloud and reflecting on the application within a short time.

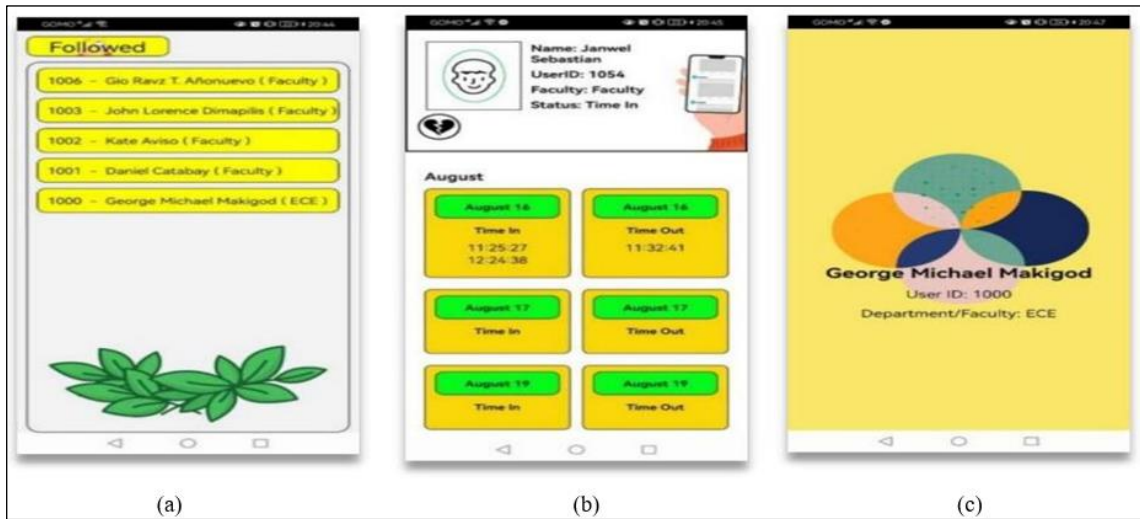

Figure 5: GUI of the mobile application: (a) Follower profiles, (b) Time and dates, and (c) Profile of user. Source: Authors, (2024).

III.2 EVALUATING THE SYSTEM

The study tested an automated attendance system using facial recognition by comparing its speed to existing biometric systems. Researchers recorded the time it took to recognize registered participants and compared it to existing systems. A paired t-test was used to determine which system performed better in terms of speed, as speed refers to the time it takes for both systems to log an attendance. The aim was to provide a more efficient way to log in attendance. The paired t-test formula is as follows:

$$t = \frac{\sum d}{\sqrt{\frac{n(\sum d^2) - (\sum d)^2}{n}}} \quad (1)$$

where:

d = difference per paired value

n = number of samples

$\sum d$ = \sum of the differences

The system is evaluated by comparing the match distance value of a user's reference image to a scanned device image. They used a different device with the same facial recognition program but different camera hardware specifications, as shown in Table 1.

Table 1: Camera Specifications.

SPECIFICATIONS	LAPTOP CAMERA	ORASHARE WB-01 HD WEB CAMERA
Megapixels	0.9MP	2.1MP
Aspect Ration	16:9	16:9
Resolution	1280x720	1920x1080
Frames per Second	30fps	30fps
Refresh Rate	60Hz	75Hz

Source: Authors, (2024).

The match distance value is a numerical measure that quantifies the similarity between a scanned image and a reference image. The most common match distance value for facial recognition programs is 0.6, but these values are prone to inaccuracy. In a study evaluating the AI facial recognition system, researchers set a threshold of 0.37 to ensure accurate recognition and minimize misidentifications. This threshold was determined through empirical observations and practical insights, balancing the risk of missed identifications and false positive matches. Overly strict threshold values often resulted in missed identifications, while too lenient thresholds posed risks of false positive matches. The selection of the 0.37 threshold was guided by practical considerations and an empirical understanding of the system's behavior, demonstrating its ability to differentiate between authorized users and guard against errors. Accuracy was calculated based on the match distance value and facial recognition results. Accuracy Percentage of Match Distance Value:

$$Accuracy = [1 - matchdistance] \times 100 \quad (2)$$

The system was evaluated by testing the maximum distance a user could be recognized, using distances from 2ft, 4ft, and 6ft. The accuracy of the match distance value was measured, and results were averaged per distance. The prototype was also evaluated by placing two registered users in front of it, with three tests: one where User A was far from the camera, one where User B was near, and one where both users were in the same position.

IV. RESULTS AND DISCUSSIONS

The IoT based automated attendance system using facial recognition was brought to the Cavite State University Main Campus, College of Engineering and Information Technology for performance evaluation. The device was treated as an independent attendance system for its performance. The system had a total of 100 registered users.

To compare the speed of the prototype in logging an attendance, it was compared to an existing biometric attendance

system developed by [12]. The data in their study was extracted from Figure 5 in their journal article.

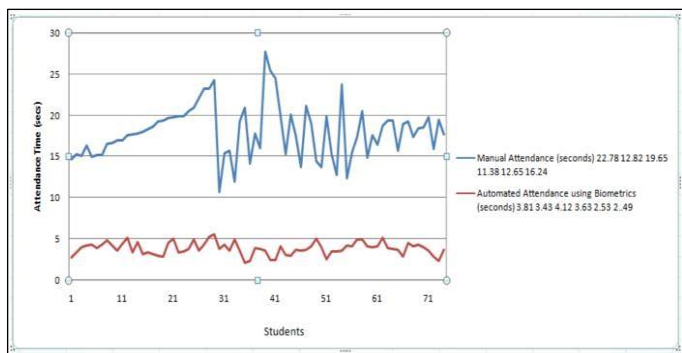

Figure 5: Comparison of manual attendance with Attendance Management System. Source: [12]

The prototype of a biometric attendance system developed by [12], was compared to an existing system tested on 80 students. The prototype was found to be 19.89% faster than the fingerprint

system, consuming an average of 3.152167 seconds in logging attendance.

Table 2. Comparison Result of Prototype’s Speed Compared To An Existing Attendance System.

Number of Users	Fingerprint Attendance System	Prototype’s Speed in Recognizing
80	3.935625	3.152167

Source: Authors, (2024).

The Paired T-test test was employed to objectively ascertain whether there was a significant difference in the speeds of the two approaches. The null hypothesis states that the existing biometrics attendance system performs better than prototype in terms of speed, while the alternative hypothesis states that the prototype performs better than the existing biometrics attendance system. The analysis used a 0.05 level of significance. The calculations were done using IBM SPSS Statistics Software. The result of the analysis is shown in Table 3.

Table 3: Paired T-test Table Calculated in IBM SPSS Statistics Software.

PAIRED SAMPLES TEST										
Paired Differences									Significance	
					95% Confidence Interval of the Difference					
		Mean	Std. Deviation	Std. Error Mean	Lower	Upper	t	df	One-Sided P	Two-Sided P
Pair 1	Fingerprint Prototype	.78346	.62943	.7037	.64338	.92353	11.133	79	<.001	<.001

Source: Authors, (2024).

A paired T-test was conducted to compare the performance of their prototype with an existing biometrics attendance system. The results showed a mean difference of approximately 0.78346 between the two systems, with a standard deviation of 0.62943 and a standard error of 0.7037. The 95 percent confidence interval ranged from 0.64338 to 0.92353, with a computed t-value of 11.133 indicating a strong difference between the prototype's performance and the null hypothesis value.

The paired t-test results supported the null hypothesis that there was no difference between the systems in favor of the prototype. The two-sided p-value was also less than 0.001, further reinforcing this conclusion. The prototype outperformed the fingerprint attendance system significantly, with an average improvement of approximately 0.78345. To measure the accuracy of the match distance value, the researchers conducted a cross-camera performance evaluation using a standard laptop camera. The average match distance value a standard laptop camera can generate is 0.445293 or 0.45, with an average accuracy of 56 percent. These findings highlight the superiority of the system and the potential of the prototype in improving biometrics attendance systems.

Table 4: Average of the data recorded using standard laptop camera.

NUMBER OF TESTS	LAPTOP CAMERA (Average Match Distance Value)	ACCURACY OF MDV (Average)
10	0.445293	56%

Source: Authors, (2024).

The prototype's camera generated an average match distance value of 0.309119, with an accuracy percentage of 69%. The scanned user's match distance value was less than the 0.37 threshold, indicating that the system recognized the user 10 times out of 10 tests.

Table 5: average of the data recorded using the prototype’s camera.

NUMBER OF TESTS	LAPTOP CAMERA (Average Match Distance Value)	ACCURACY OF MDV (Average)
10	0.309119	69%

Source: Authors, (2024).

Table 6 compares two cameras, showing a standard laptop camera has an average 56% match distance value accuracy rate, while the prototype's camera has an average of 69%, indicating a 14 percent difference in accuracy.

Table 6: Average of the match distance value accuracy of both cameras.

	LAPTOP CAMERA (Average MDV Accuracy)	PROTOTYPE'S CAMERA (Average MDV Accuracy)	DIFFERENCE
Average	56%	69%	14%

Source: Authors, (2024).

A prototype laptop camera's cross-camera performance was evaluated, finding it more accurate in match distance values compared to a standard camera. They tested the camera's maximum distance for user recognition, using distances of 2ft, 4ft, and 6ft. Results showed match distance values were less than 0.37 at 2ft and 4ft, but more than 0.37 at 6ft, indicating that 6ft distance is not acceptable. The ideal distances for a user to stand from the prototype are 2ft to 4ft, with the results shown in Table 7.

Table 7: Tabulated data of the results based on the distance test.

DISTANCE	TEST 1 (MDV)	TEST 1 (MDV)	TEST 1 (MDV)	AVERAGE ACCURACY
2ft	0.33184048	0.31100299	0.32514012	68%
4ft	0.36820279	0.33120573	0.33731981	65%
6ft	0.37860146	0.40556667	0.41409713	60%

Source: Authors, (2024).

Three tests was conducted to determine the priority of users in scanning a camera. The tests involved two users, one far from the camera and the other near it. The results showed that the program prioritized the far user 4 out of 10 times, indicating that not all users near the camera will be recognized. The program prioritized the near user 6 out of 10 times, with a match distance value accuracy rate of 59%. The program also recognized the far user 40% of the time, with a match distance value accuracy rate of 41%. Both users had an average of 19% difference in recognition.

Table 8: Average of data recorded for test 1.

NUMBER OF TRIALS	USER A (FAR) (Average MDV Accuracy)	USER B (NEAR) (Average MDV Accuracy)	DIFFERENCE
10	41%	59%	19%

Source: Authors, (2024).

In Test 2, the program prioritized User A near the camera 7 out of 10 times, while User B was far. The program prioritized User A 70 percent of the time with a match distance accuracy rate of 51%, while User B was 3 percent of the time with a 47 percent was 3 percent of the time with a 47 percent accuracy rate. Both users had an average of 4% difference in accuracy rate.

Table 9: Average of data recorded for test 2.

NUMBER OF TRIALS	USER A (NEAR) (Average MDV Accuracy)	USER B (FAR) (Average MDV Accuracy)	DIFFERENCE
10	51%	47%	4%

Source: Authors, (2024).

In Test 3, the program prioritized User A over User B when both users stood at the same distance from the camera. User A was only recognized 30% of the time with a 38% match distance value accuracy rate, while User B was recognized 70% of the time with a 58% accuracy rate. User A had an average match distance value of 0.621007, while User B had an average of 0.4186554. User A's higher value suggests that User B was more recognizable than User A, as the threshold value set by the researchers was 0.37. The results may be due to feature extraction and minor pose variations, as User B's facial features were more distinctive and pronounced compared to User A.

Table 10: Average of data recorded for test 3.

NUMBER OF TRIALS	USER A (Average MDV)	USER A (Average MDV Accuracy)	USER B (Average MDV)	USER B (Average MDV Accuracy)	MOST REOGNIZE R D USER
10	0.621007	38%	0.4186554	58%	User B (7/10)

Source: Authors, (2024).

V. CONCLUSIONS

The study developed an IoT-based automated attendance system using facial recognition, which was successfully implemented. The system provided students, professors, and parents with comprehensive attendance records, with an intuitive design that matched diverse needs. The system outperformed traditional methods with an average time efficiency of 3.16 seconds and an accuracy rate of 69%. However, the system only scanned and logged attendance, not showing the exact location of the person inside the institution. Future research could explore liveness detection experiments to enhance facial recognition systems' robustness and security.

VII. ACKNOWLEDGMENTS

The authors express their gratitude to Dr. Edwin R. Arboleda, a thesis adviser, Engr. Lemuel G. Tatad, a technical critic, Ms. Poinsettia A. Vida, the unit research coordinator, Dr. Willie C. Buclatin, the Dean of the College of Engineering and Information Technology, Dr. Michael T. Costa, Engr. Rose Ann E. Sumadsad, Engr. Rhodonelle S. Duatin, Engr. Miguel Joseph L. Jacoba, and Engr. Cenon D. Lumabad III, the review panel, all participants in the study, especially the two sections of students, for their invaluable contributions and support. They also thank God for his unending knowledge, guidance, and support.

VIII. REFERENCES

- [1] Ravalji, R., Shah, N., Patel, H., & Patel, M. (2020). FACIAL RECOGNITION-BASED ATTENDANCE SYSTEM USING PYTHON. International Research Journal of Engineering and Technology. www.irjet.net
- [2] Sri Madhu, B. M., Kanagotagi, K., & Devansh. (2018). IoT based Automatic Attendance Management System. International Conference on Current Trends in Computer, Electrical, Electronics and Communication, CTCEEC 2017, 83–86. <https://doi.org/10.1109/CTCEEC.2017.8455099>
- [3] Alhanaee, K., Alhammadi, M., Almenhali, N., & Shatnawi, M. (2021). Face recognition smart attendance system using deep transfer learning. Procedia Computer Science, 192, 4093–4102. <https://doi.org/10.1016/j.procs.2021.09.184>
- [4] Kovelan, P., Thisentira, N., & Kartheeswaran, T. (n.d.). Automated Attendance Monitoring System Using IoT.
- [5] Anand, V., Singh Parihar, V., Sharma, S. K., Singhal, V., & Sethy, P. K. (2021). FACIAL RECOGNITION SYSTEM USING OPENCV. In International Journal of Creative Research Thoughts (Vol. 9, Issue 7). www.ijcrt.org
- [6] Olanipekun, A. A., & Boyinbode, O. K. (2015). A RFID based automatic attendance system in educational institutions of Nigeria. International Journal of Smart Home, 9(12), 65–74. <https://doi.org/10.14257/ijsh.2015.9.12.07>
- [7] Rjeib, H. D., Ali, N. S., Al Farawn, A., Al-Sadawi, B., & Alsharqi, H. (2018). Attendance and information system using RFID and web-based application for academic sector. International Journal of Advanced Computer Science and Applications, 9(1), 266–274. <https://doi.org/10.14569/IJACSA.2018.090137>
- [8] Konatham, S., Surya Chalasani, B., Kulkarni, N., & El Taeib, T. (n.d.). ATTENDANCE GENERATING SYSTEM USING RFID AND GSM.
- [9] MB, S., & Roy, R. (2015). A Web Secured System for Attendance Monitoring and Real Time Location Tracking Using Biometric and Radio Frequency Identification (RFID) Technology. 653-657
- [10] Rahman, S., Rahman, M., & Rahman, M. M. (2018). Automated Studen System using Fingerprint Recognition. Edelweiss Applied Science and Techno <https://doi.org/10.33805/2576.8484.120>
- [11] Akinduyite, O. C., Adetunmbi, A. O., Ibidunmoye, O., & Olabode, O. O. (2013). Fingerprint-Based Attendance Management System. Journal of Computer Sciences and Applications, 1(5), 100–105. <https://doi.org/10.12691/jcsa-1-5-4>
- [12] Oluwagbemiga, E., Shoewu, O., Idowu, O., Shoewu, O., & Idowu, O. A. (2012). Development of Attendance Management System using Biometrics Robotics and Systems View project Electronics View project Development of Attendance Management System using Biometrics. In The Pacific Journal of Science and Technology (Vol. 13, Issue 1). <http://www.akamaiuniversity.us/PJST.htm>
- [13] Damale, R. C., & Pathak, Bazeshree. V. (2018). Face Recognition Based Attendance System Using Machine Learning Algorithms. 2018 Second International Conference on Intelligent Computing and Control Systems (ICICCS), 414–419. <https://doi.org/10.1109/ICCONS.2018.8662938>
- [14] Suresh, V., Chakravarthi Dumpa, S., Deepak Vankayala, C., & Rapa, J. (2019). Facial Recognition Attendance System Using Python and OpenCv. In Quest Journals Journal of Software Engineering and Simulation (Vol. 5, Issue 2). www.questjournals.org
- [15] Aware, M., Labade, P., Tambe, M., Jagtap, A., & Beldar, C. (2021). Attendance Management System using Face-Recognition. International Journal of Scientific Research in Computer Science, Engineering and Information Technology, 336–341. <https://doi.org/10.32628/cseit217370>
- [16] Emami, S., & Suci, V. P. (2012). Facial Recognition using OpenCV FaceBots View project Facial Recognition using OpenCV. www.jmeds.eu
- [17] Wang, N. J., Chang, S. C., & Chou, P. J. (2012). A real-time multi-face detection system implemented on FPGA. ISPACS 2012 - IEEE International Symposium on Intelligent Signal Processing and Communications Systems, 333–337. <https://doi.org/10.1109/ISPACS.2012.6473506>
- [18] Silwal, V., & Panicker, A. (2019). Facial Detection and Facial Recognition using OpenCV. <http://ijesc.org/>.
- [19] Bin Sulaiman, R., Kareem, A., & Saber Nipun, M. (n.d.). Efficiency Comparison of AI classification algorithms for Image Detection and Recognition in Real-time.